

# STAND<sup>OUT</sup>

be visible

## SIGNAGE CATALOG

---

VALID FOR VIECON

2026

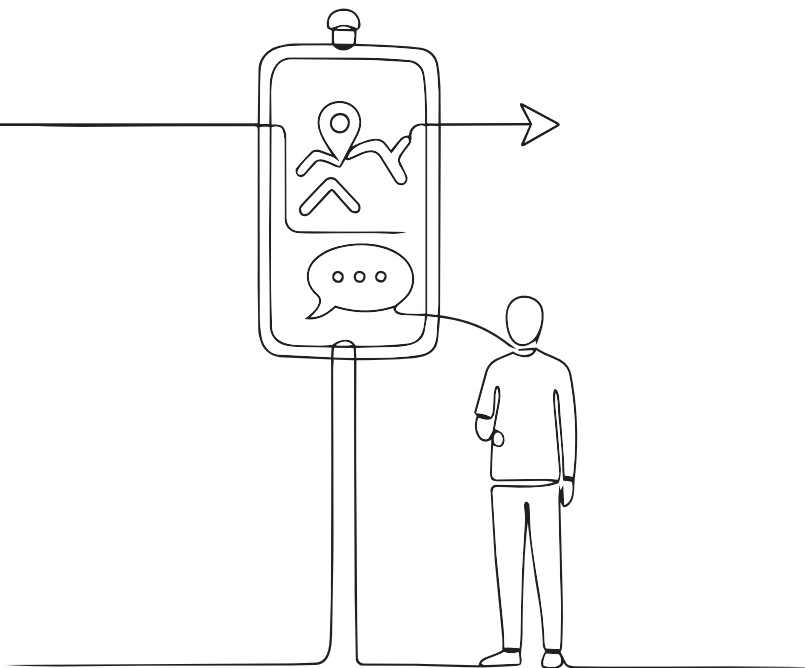

**LIVE EVENTS**



**DIGITAL STAGE**



**BRANDING**

# STAND<sup>OUT</sup>

be visible

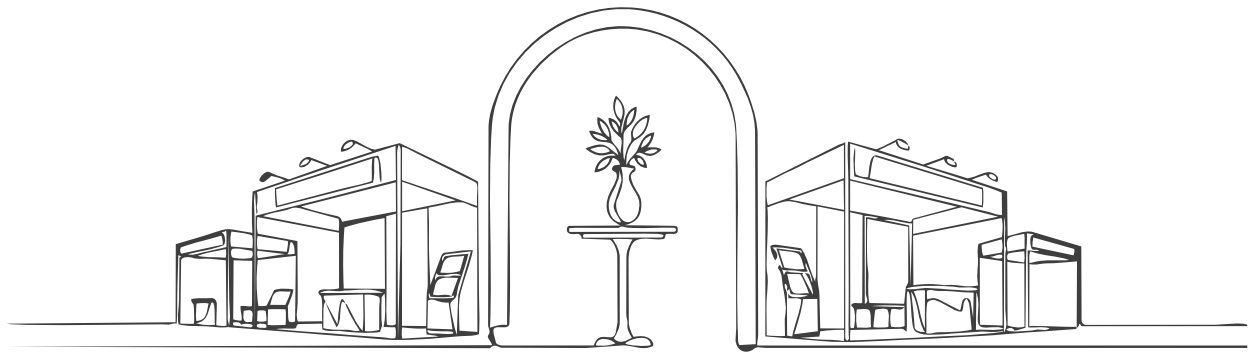

## SIGNAGE „FOYER A“

---

AND SURROUNDING

2026



# EXHIBITION CENTER

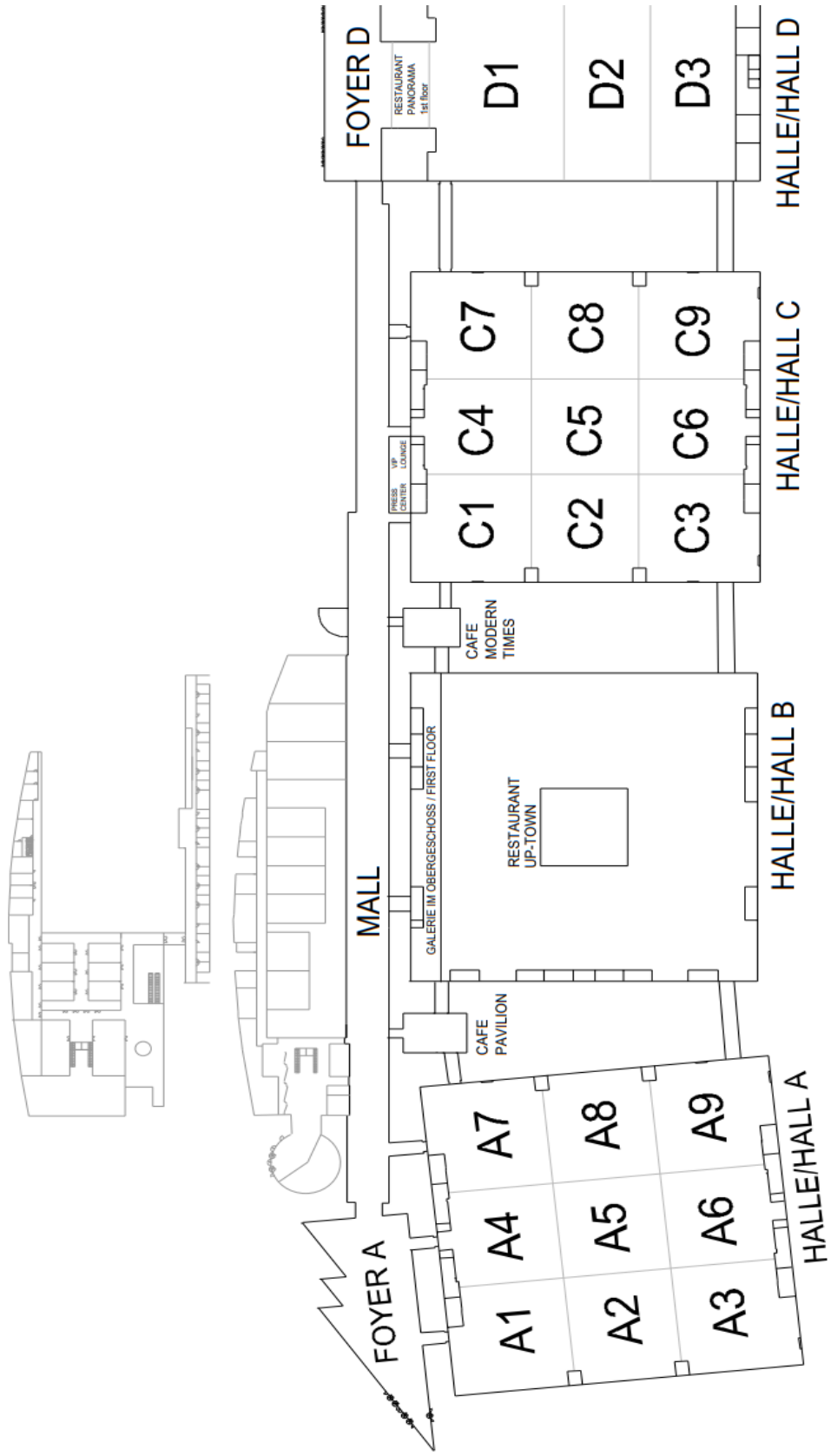

**CODE: AG1 - 6**

<b>Position</b>	<b>flag for flagpoles outside Foyer A</b>		
Dimension (WXH)	1 200 mm	8 000 mm	
Visible Area (WXH)	1 200 mm	8 000 mm	
Sides	single sided		
Material	flag fabric, rattling flag		
Total pieces	6		

Unit Price 297,30 €

Price Total 1 783,80 €



mounting of flags will be done and charged by Reed Messe

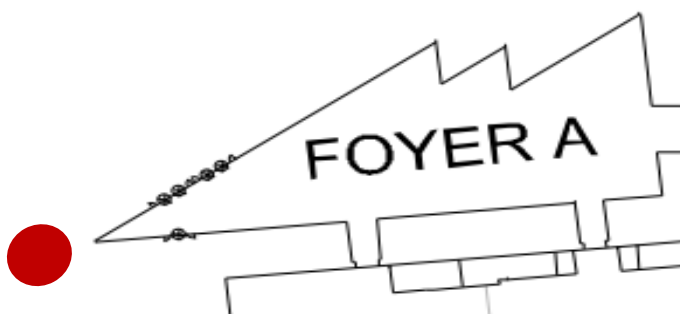

**CODE: AG14b, AG15b, AG16b**

<b>Position</b>	<b>signage on totem in front of Halle A</b>		
Dimension (WxH)	2 179 mm	2 300 mm	
Visible Area (WxH)	925 mm	2 300 mm	
Sides	front/back = double sided		
Material	PVC		
Total pieces	3		

Unit Price 316,00 €

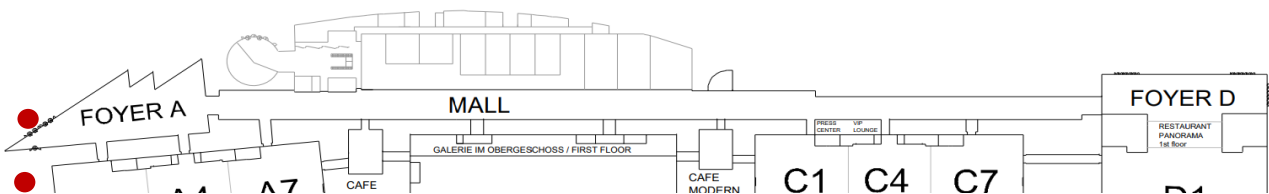
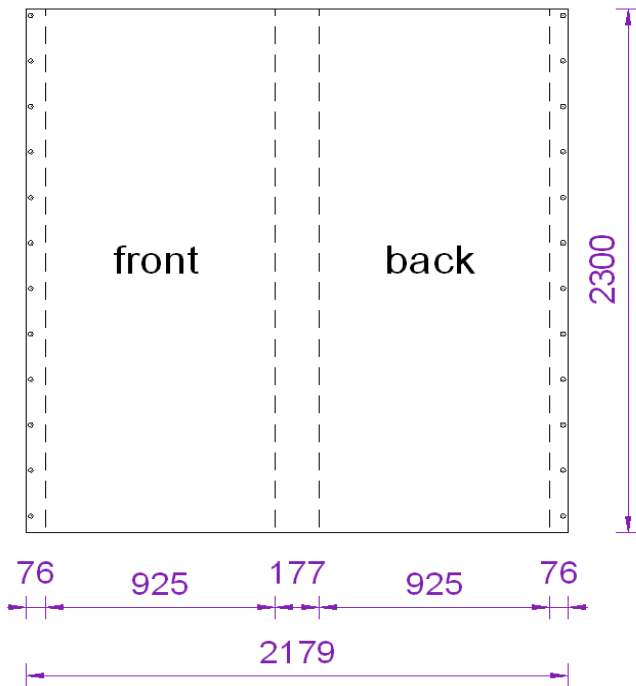

**CODE: AG14a / AG15a / AG16a**

<b>Position</b>	<b>signage on totem in front of Hall A</b>		
Dimension (WxH)	2 179 mm	5 090 mm	
Visible Area (WxH)	925 mm	5 090 mm	
Sides	front/back = double sided		
Material	PVC		
Total pieces	3		

Unit Price 625,50 €

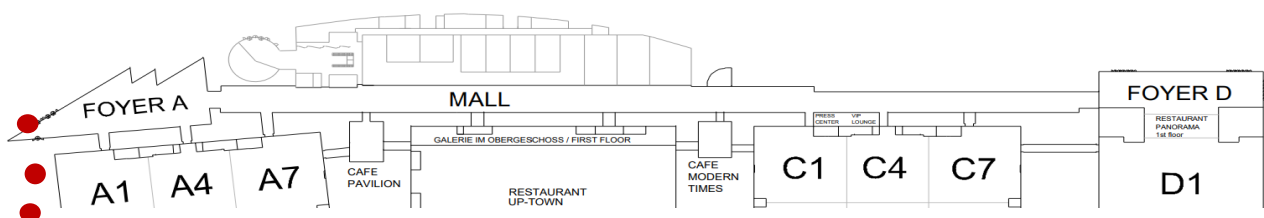
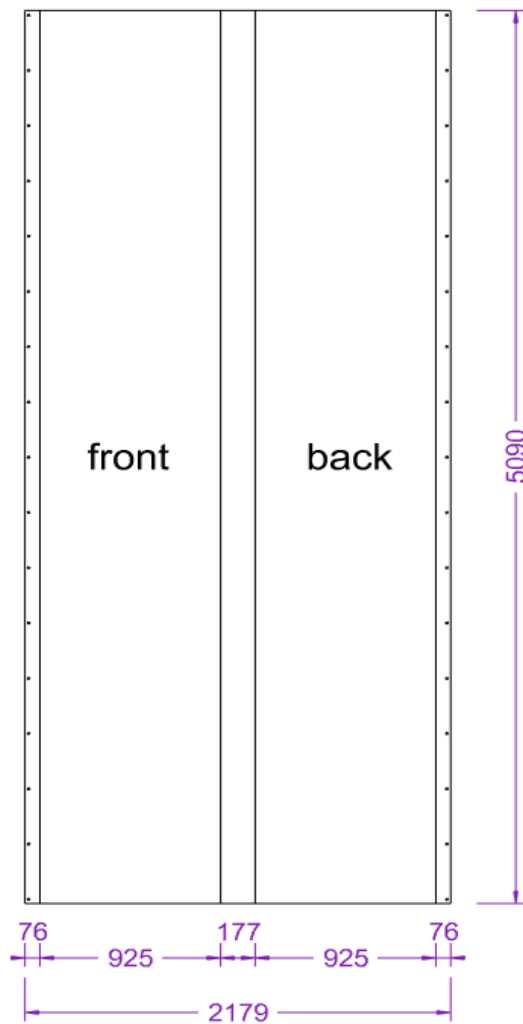

**CODE: FA-GL**

Position	<b>branding of glass panels Foyer A outside</b>		
Dimension (WxH)	9 183 mm	4 343 mm	
Visible Area (WxH)	3 028 mm	2 149 mm	
Sides	single sided		
Material	self adhesive foil		
Total pieces	6		

Unit Price 786,70 €

Price Total 4 720,20 €

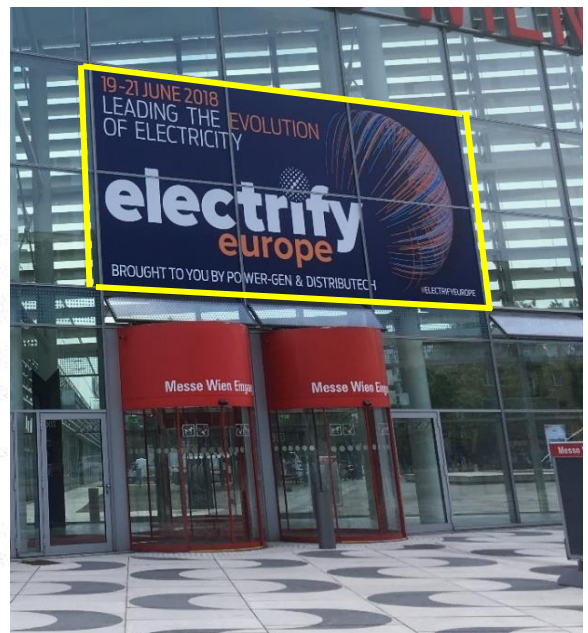
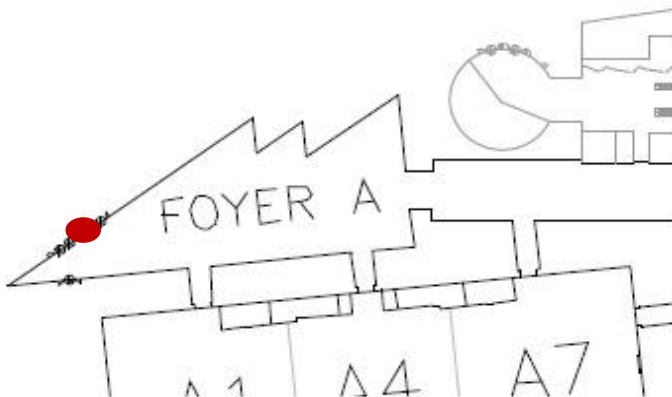
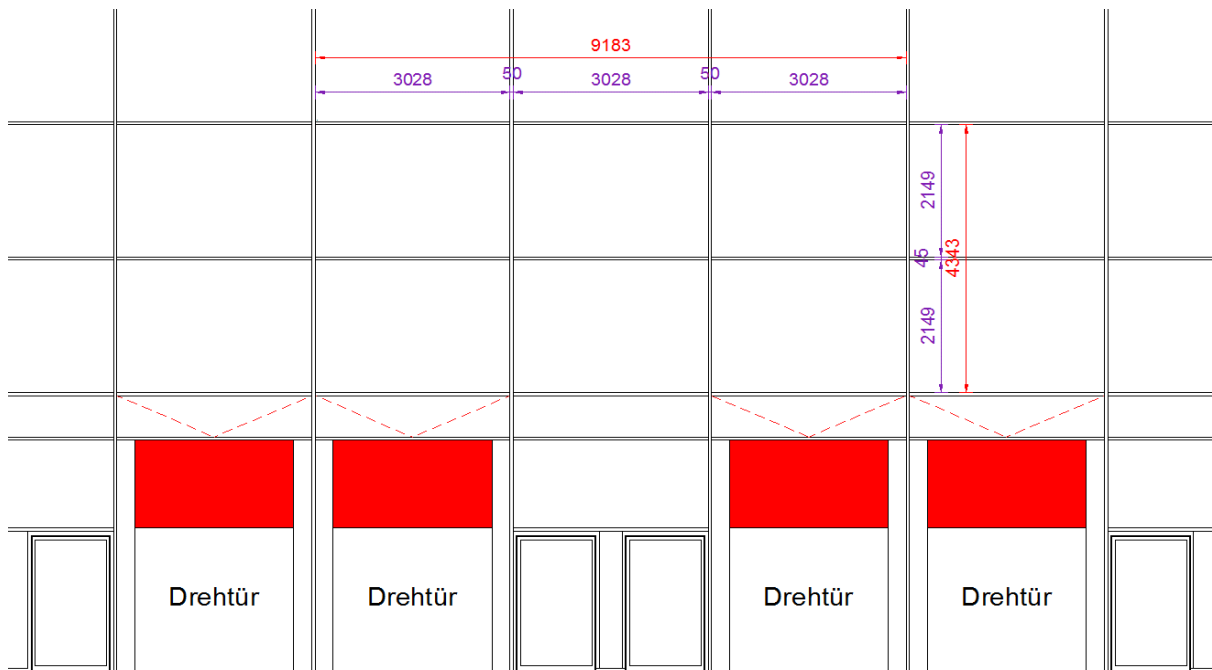

**CODE: REV1**

Position		<b>branding of outer windows of revolving doors Foyer A</b>	
Dimension (WxH)		1 090 mm	2 220 mm
Visible Area (WxH)		1 090 mm	2 220 mm
Sides		single sided	
Material		self adhesive foil	
Total pieces		20	(5 doors are available in total)

Unit Price 237,20 €

Price Total 4 744,00 €

each door has 2 outed windows (fix glass panel) outside, and 2 inside

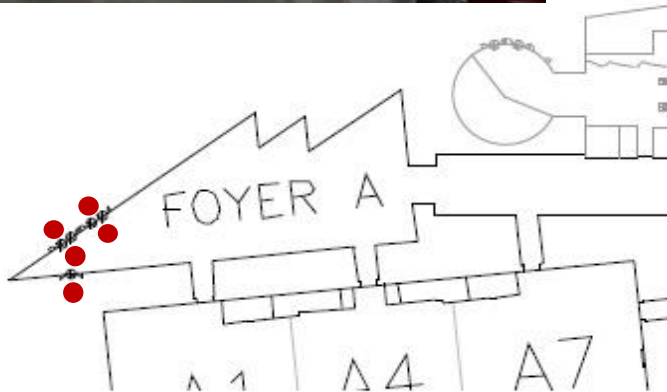
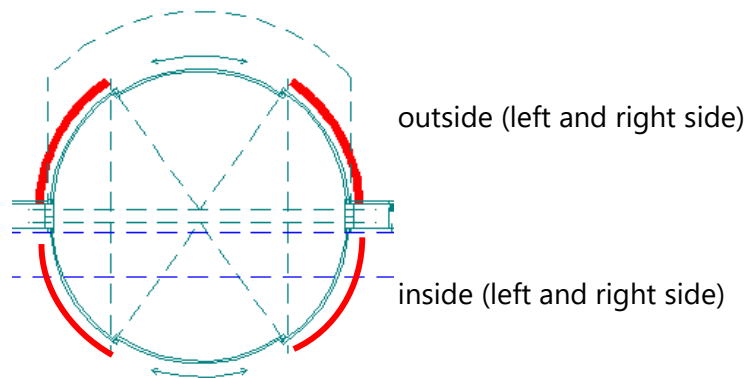

**CODE: REV2**

Position	<b>branding of inner windows of revolving doors Foyer A</b>		
Dimension (WxH)	750 mm	2 225 mm	
Visible Area (WxH)	750 mm	2 225 mm	
Sides	single sided		
Material	self adhesive foil		
Total pieces	20	(5 doors are available in total)	

Unit Price 230,60 €

Price Total 4 612,00 €

each door has 2 revolving doors (sliding glass panel) outside, and 2 inside

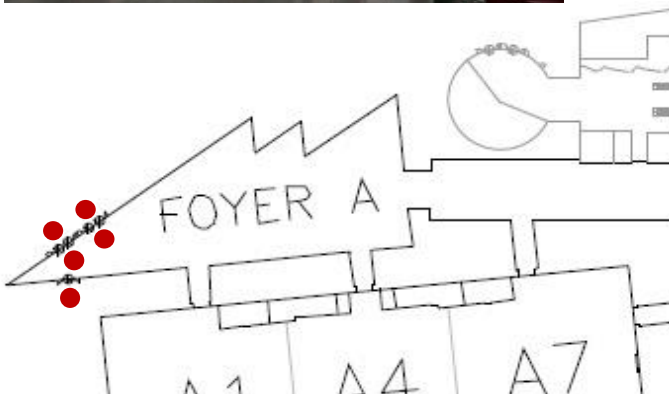
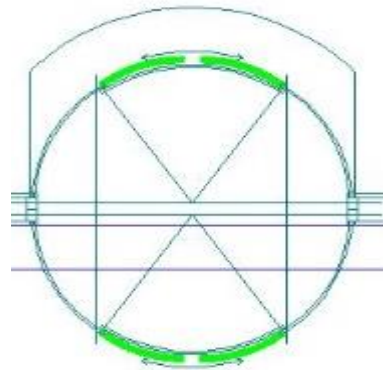

**CODE: REV3**

Position	<b>branding above revolving doors (exterior / interior) Foyer A</b>		
Dimension (WxH)	3 820 mm	1 270 mm	
Visible Area (WxH)	3 820 mm	1 270 mm	
Sides	single sided		
Material	self adhesive foil		
Total pieces	10	(5 doors are available in total)	

Unit Price (per side) 572,80 €

Price Total 5 728,00 €

each door has 1 fix red panel (above the door) outside, and 1 inside

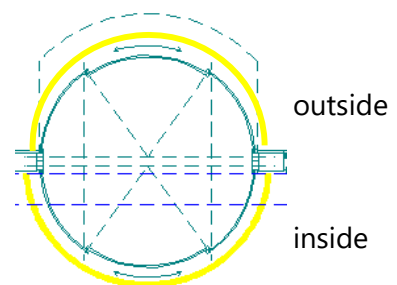
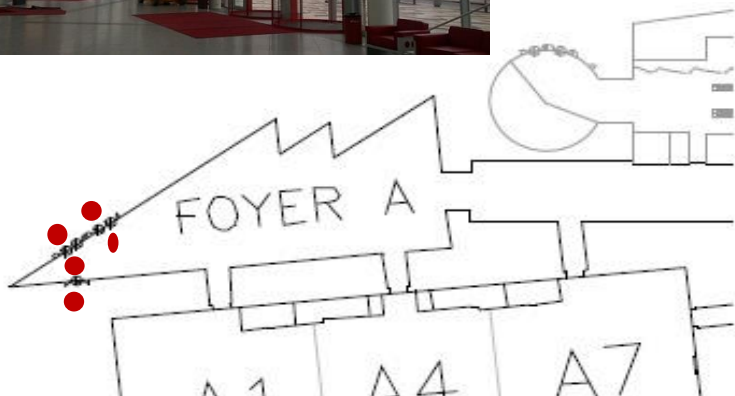
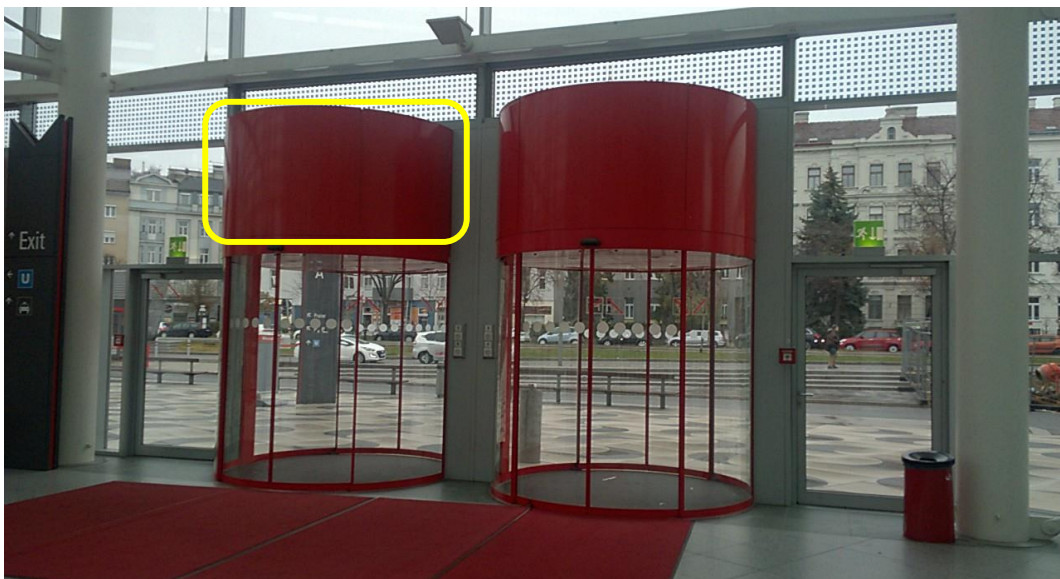

**CODE: FAB1**

Position	<b>banner entry Foyer A</b>		
Dimension (WxH)	6 000 mm	3 000 mm	
Visible Area (WxH)	6 000 mm	3 000 mm	
Sides	single side		
Material	graphic fabric		
Total pieces	1		

Unit Price 1 186,60 €

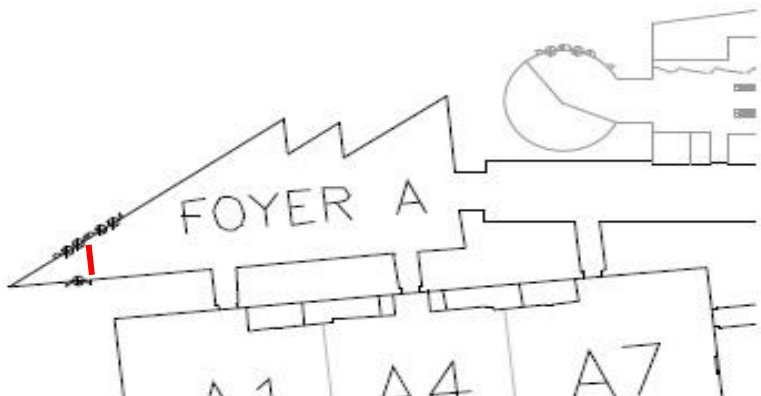
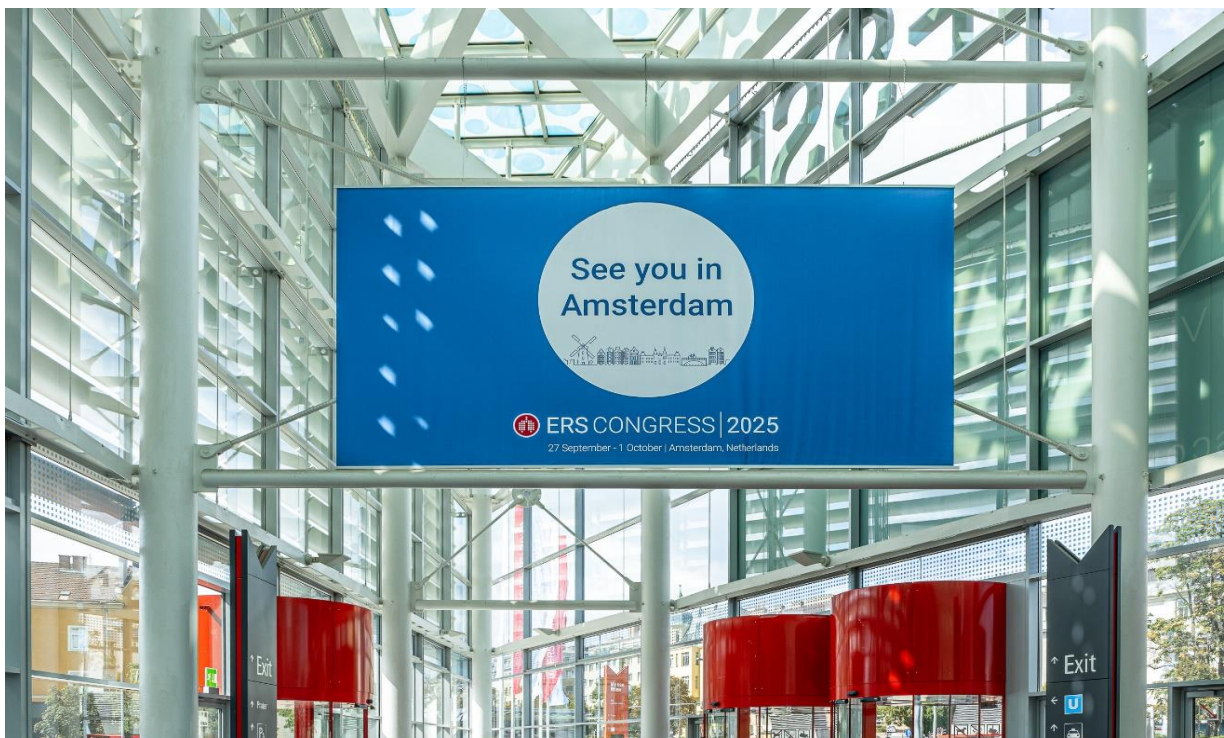

**CODE: FAB2**

Position	<b>banner above registration terminals Foyer A</b>		
Dimension (WxH)	6 000 mm	1 200 mm	
Visible Area (WxH)	6 000 mm	1 200 mm	
Sides	single sided		
Material	graphic fabric		
Total pieces	1		

Unit Price (per side) 769,40 €

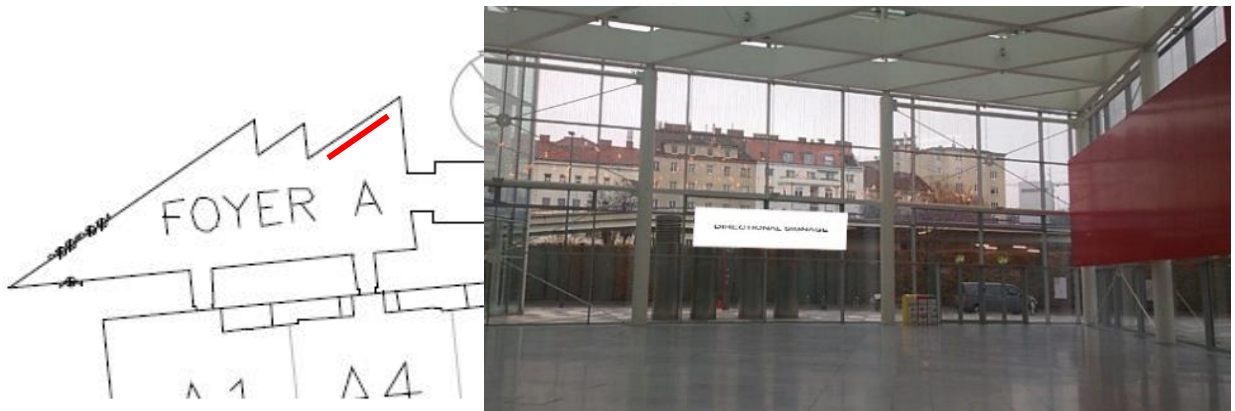
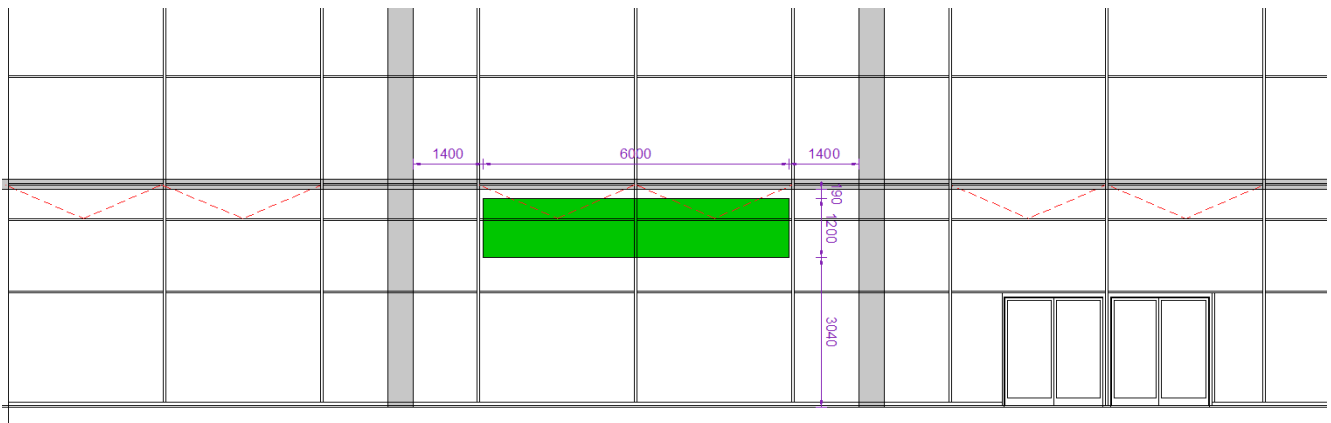

**CODE: FA1 / FA2 / FA3 / FA4**

Position	<b>signage on totem at entry</b>		
Dimension (WxH)	695 mm	3 860 mm	
Visible Area (WxH)	695 mm	3 860 mm	
Sides	single sided		
Material	forex, 3mm		
Total pieces	4		

Unit Price 220,20 €

Price Total 880,80 €

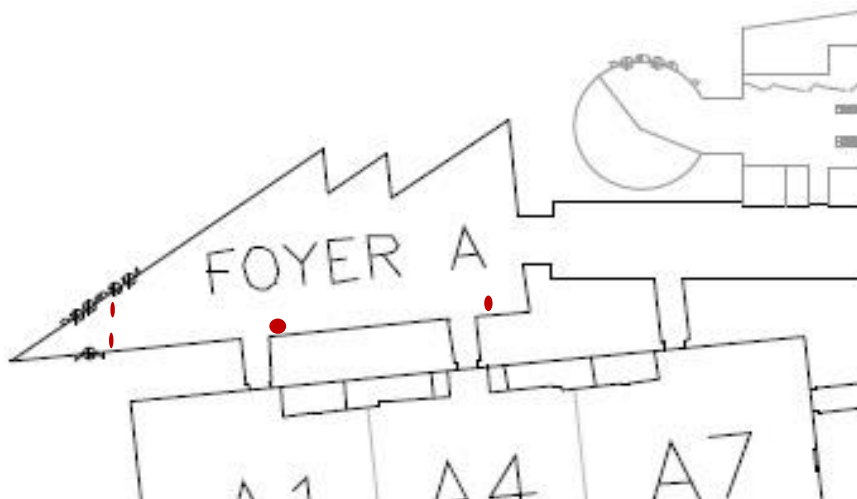
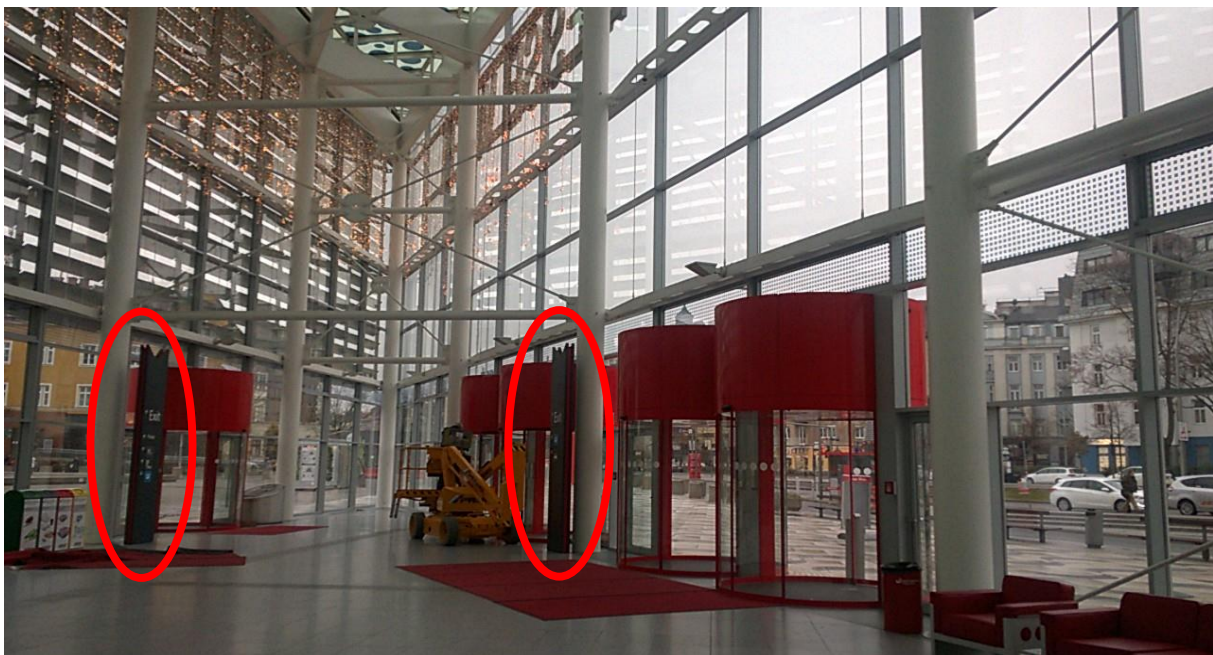

**CODE: FA5**

Position	<b>signage on totem - side A + B</b>		
Dimension (WxH)	915 mm	5	130 mm
Visible Area (WxH)	915 mm	5	130 mm
Sides	front/back = double sided		
Material	forex, 3mm		
Total pieces	2		

Unit Price (per side) 311,50 €

Price Total 623,00 €

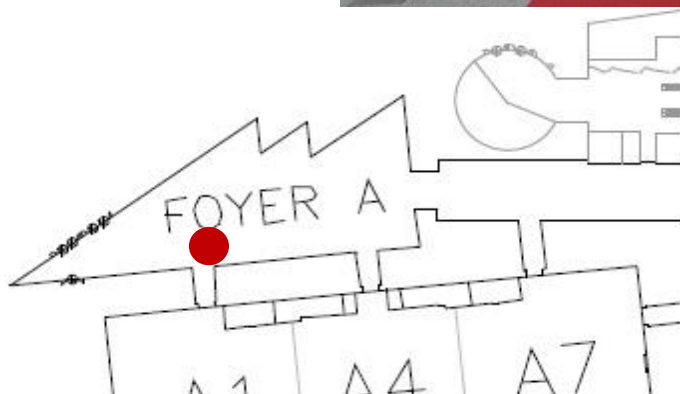
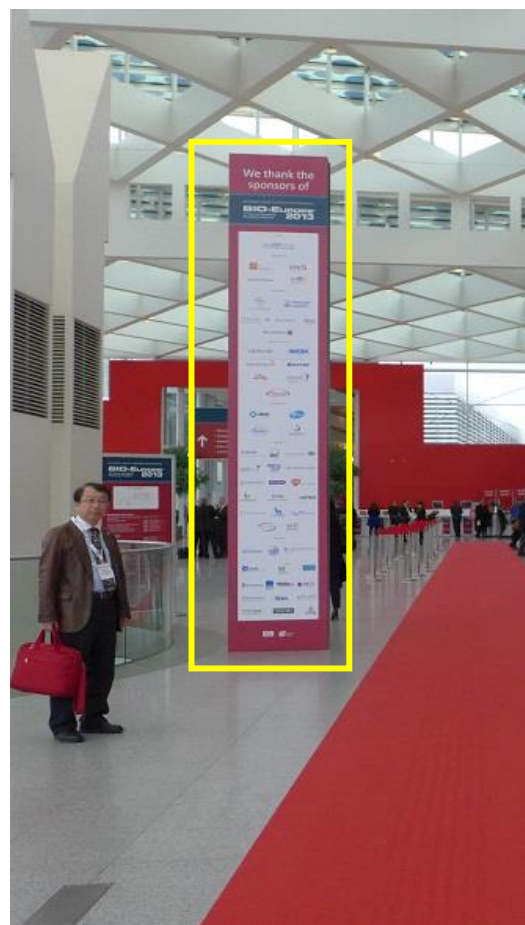

**CODE: FA6 / FA7**

Position	<b>signage on overhead signpost above entrance to Hall A</b>		
Dimension (WxH)	5 380 mm	693 mm	
Visible Area (WxH)	5 380 mm	693 mm	
Sides	single side		
Material	graphic fabric		
Total pieces	2		

Unit Price 584,10 €

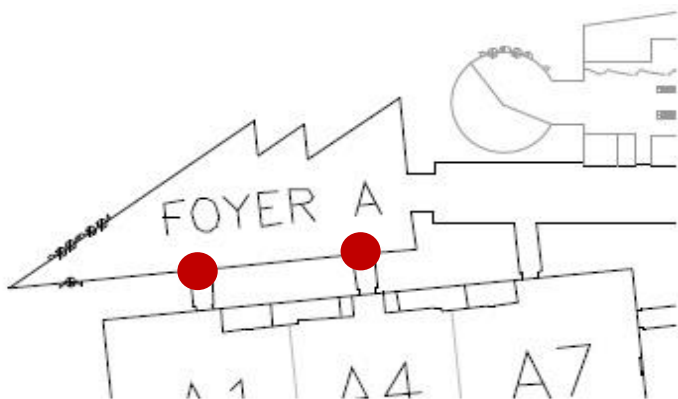

**CODE: EL1**

Position	<b>graphic cladding-elevator Foyer A - left/right</b>		
Dimension (WxH)	2 155 mm	3 580 mm	
Visible Area (WxH)	2 155 mm	3 580 mm	
Sides	single sided		
Material	graphic fabric		
Total pieces	1		

Unit Price 706,20 €

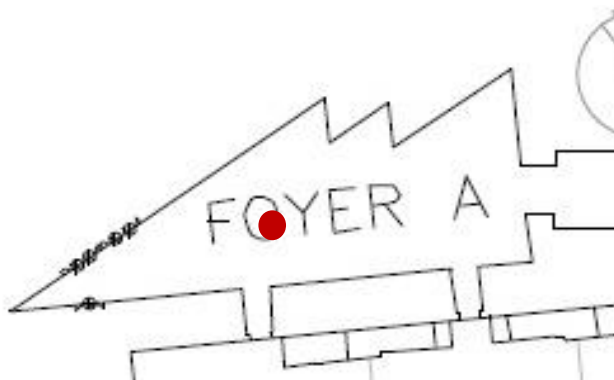
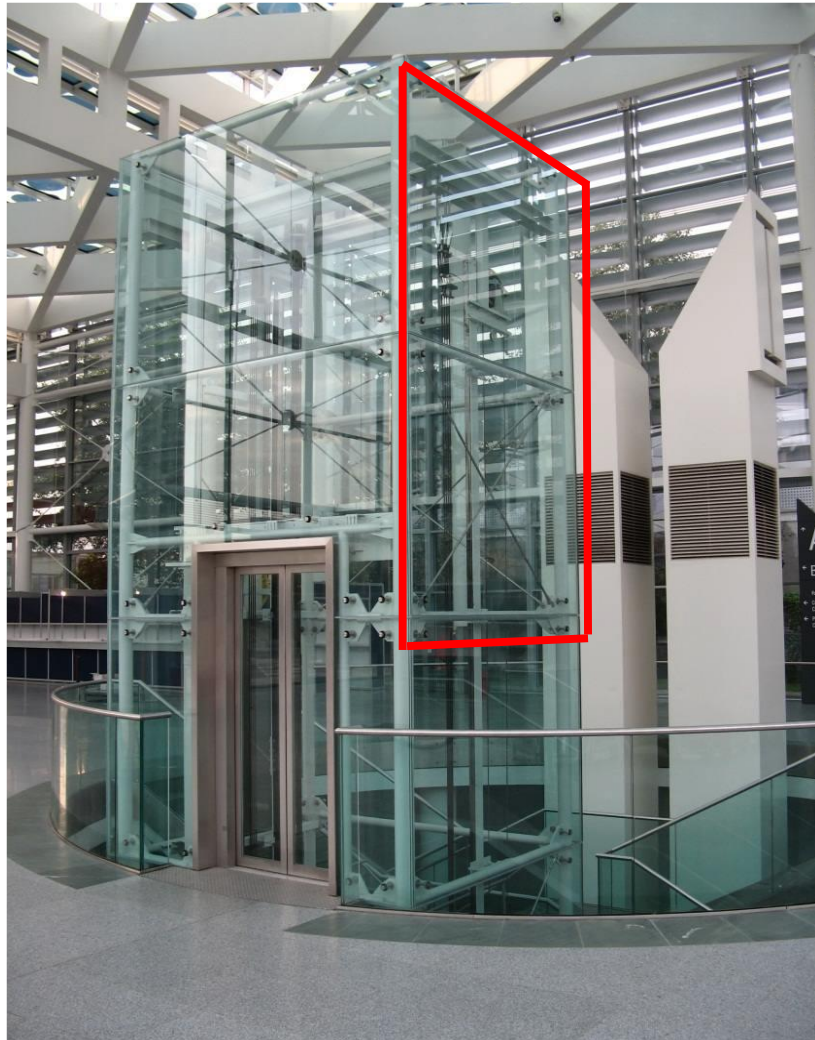

**CODE: EL2**

Position		Elevator Foyer	
Dimension (WxH)		2 155 mm	3 580 mm
Visible Area (WxH)		2 155 mm	3 580 mm
Sides		single sided	
Material		graphic fabric	
Total pieces		1	

Unit Price 706,20 €

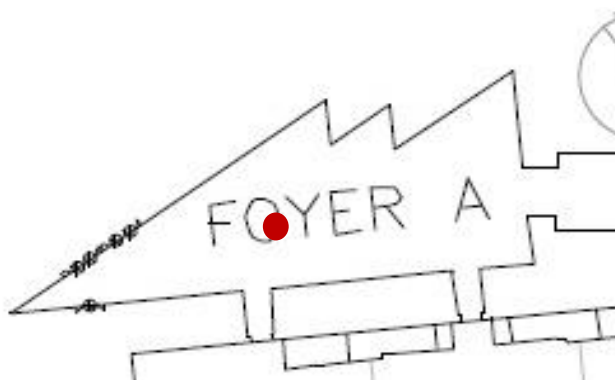
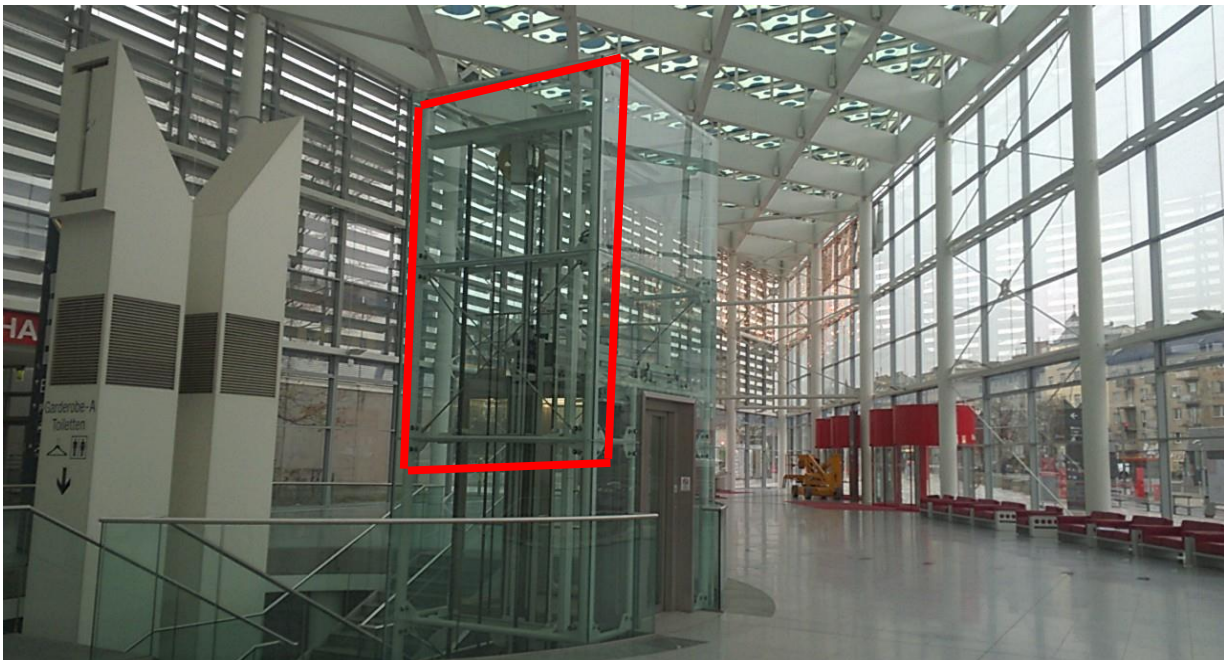

**CODE: FG1**

Position	<b>round glass right side, Foyer A</b>		
Dimension (WxH)	12 200 mm	1 030 mm	
Visible Area (WxH)	12 200 mm	1 030 mm	
Sides	single		
Material	self adhesive foil		
Total pieces	1		

Unit Price 1 142,50 €

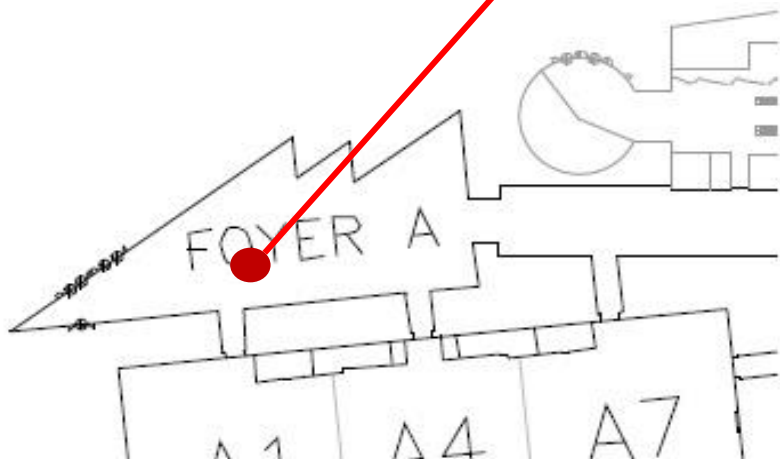

**CODE: FG2**

Position	<b>round glass left side, Foyer A</b>		
Dimension (WxH)	10 604 mm	1 030 mm	
Visible Area (WxH)	10 604 mm	1 030 mm	
Sides	single		
Material	self adhesive foil		
Total pieces	1		

Unit Price 1 137,50 €

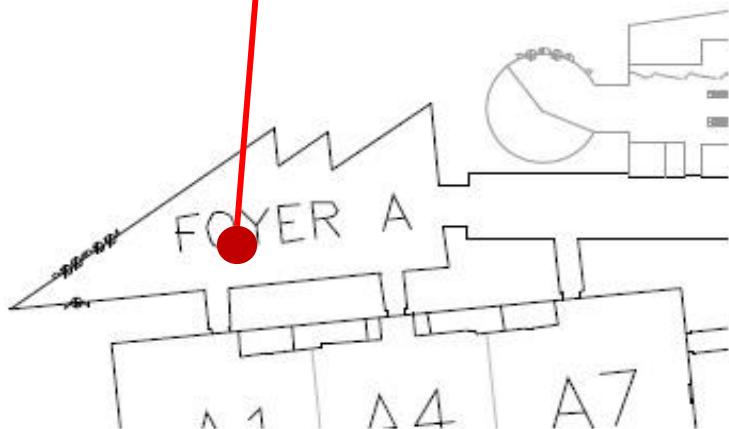
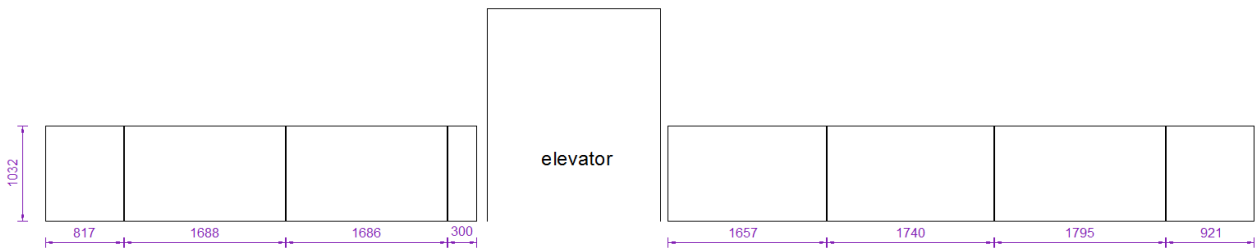

**CODE: FAB3**

Position	<b>banner above staircase Foyer A</b>		
Dimension (WxH)	4 000 mm	1 800 mm	
Visible Area (WxH)	4 000 mm	1 800 mm	
Sides	double sided		
Material	PVC		
Total pieces	1		

Unit Price 1 039,50 €

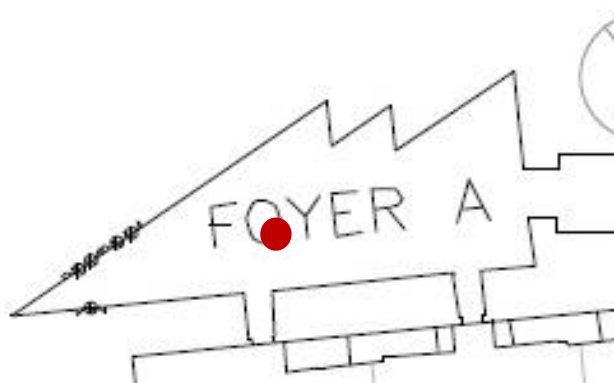

**CODE: FAB4**

Position	<b>banner mounted on interior facade Foyer A upper section</b>		
Dimension (WxH)	6 000 mm	3 000 mm	
Visible Area (WxH)	6 000 mm	3 000 mm	
Sides	single sided		
Material	graphic fabric		
Total pieces	several		

Unit Price 1 185,40 €

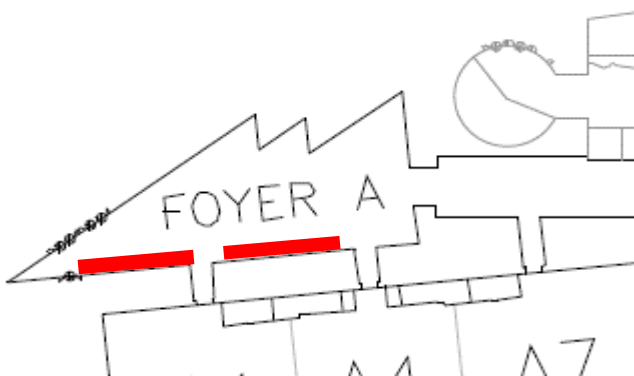
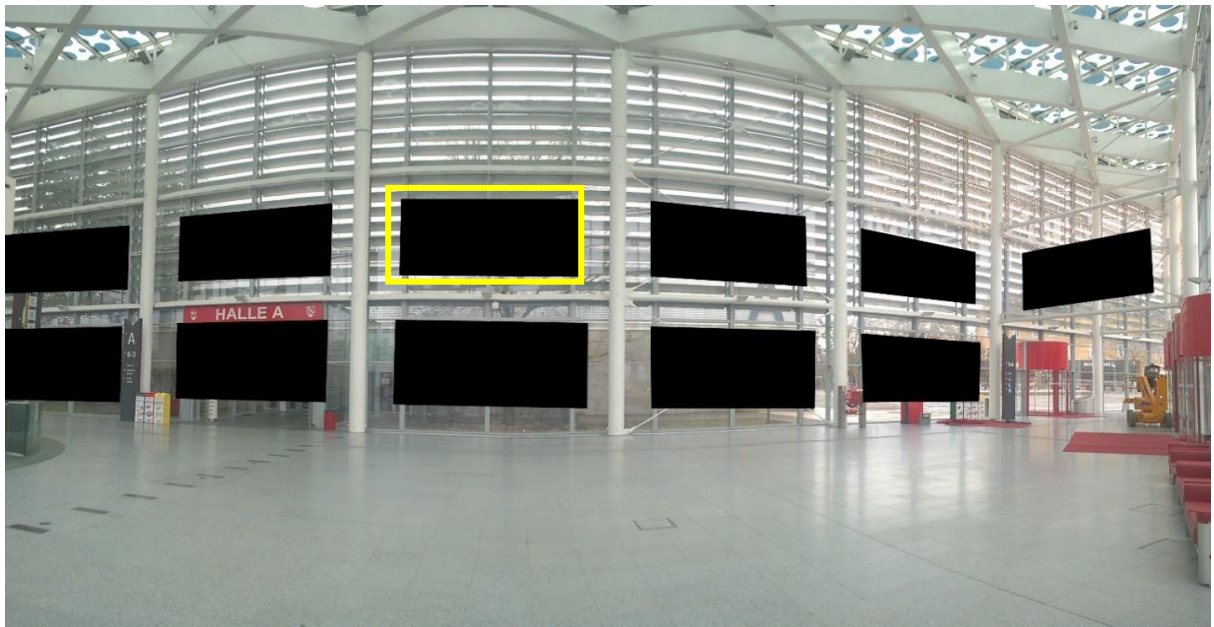
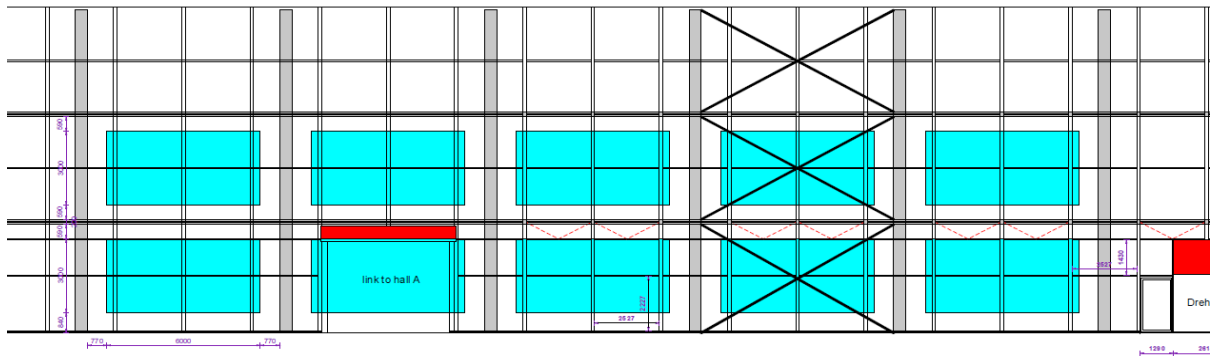

**CODE: FAB5**

Position	<b>banner mounted on interior facade Foyer A lower section</b>		
Dimension (WxH)	6 000 mm	2 400 mm	
Visible Area (WxH)	6 000 mm	2 400 mm	
Sides	single sided		
Material	graphic fabric		
Total pieces	several		

Unit Price 1 039,40 €

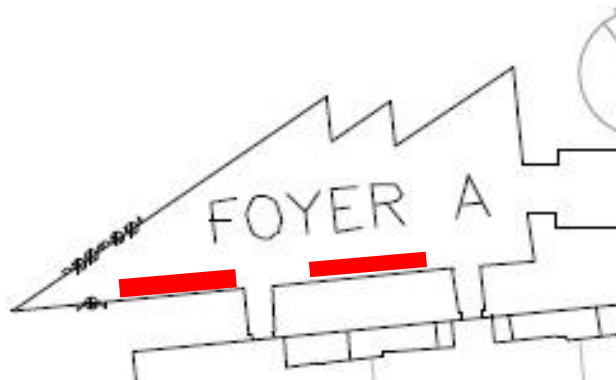
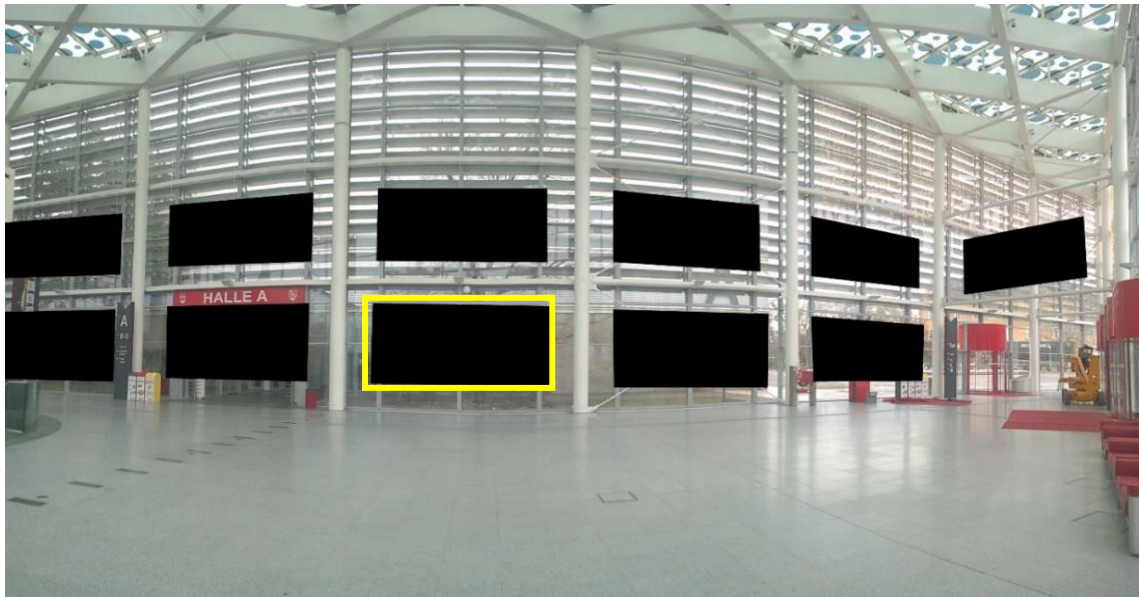
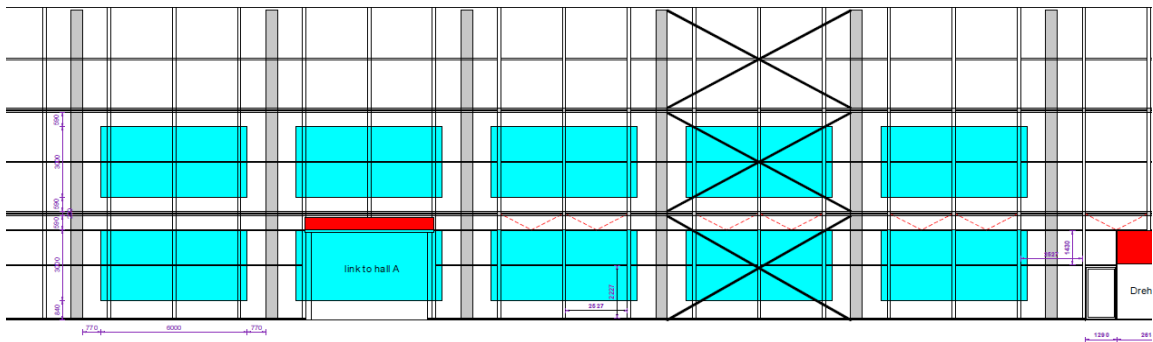

**CODE: RP1**

Position	<b>red frame branding - portal on the way to the mall Foyer A</b>		
Dimension (WxH)	15.980 mm	4.560 mm	
Visible Area (WxH)	15.980 mm	4.560 mm	
Sides	single sided		
Material	fabric material		
Total pieces	1		

Unit Price 8.257,90 €

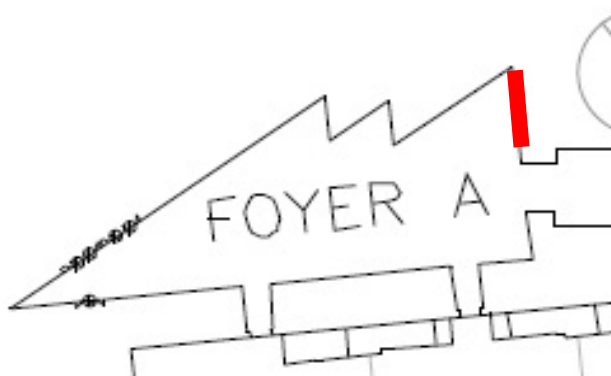
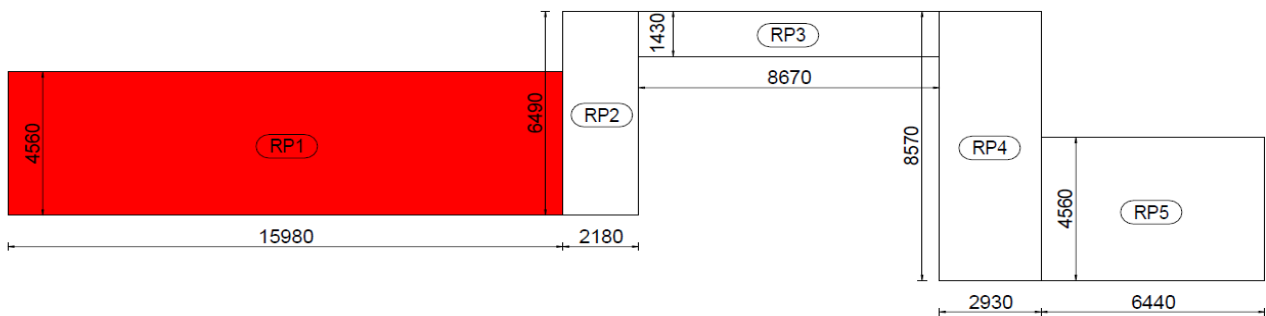

**CODE: RP2**

Position	<b>red frame branding - portal on the way to the mall Foyer A</b>		
Dimension (WxH)	2.180 mm	6.490 mm	
Visible Area (WxH)	2.180 mm	6.490 mm	
Sides	single sided		
Material	fabric material		
Total pieces	1		

Unit Price 1.895,00 €

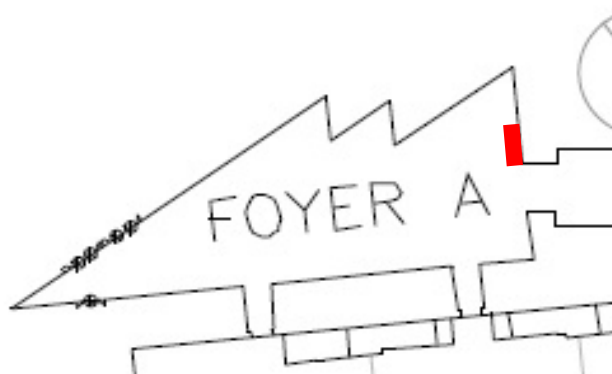
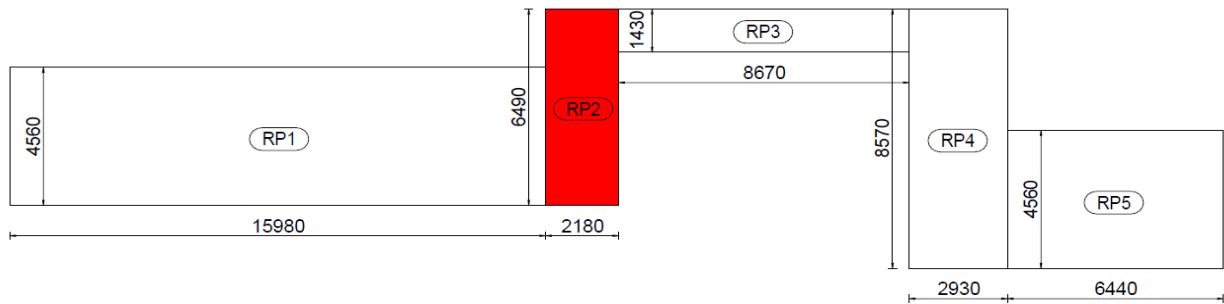
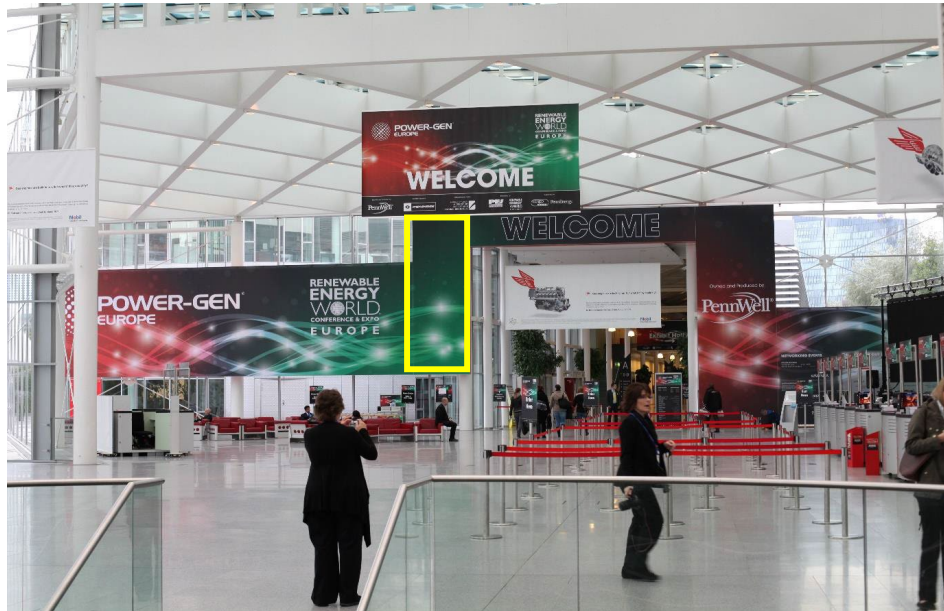

**CODE: RP3**

Position	<b>red frame branding - portal on the way to the mall Foyer A</b>		
Dimension (WxH)	8.670 mm	1.430 mm	
Visible Area (WxH)	8.670 mm	1.430 mm	
Sides	single sided		
Material	fabric material		
Total pieces	1		

Unit Price 1.647,40 €

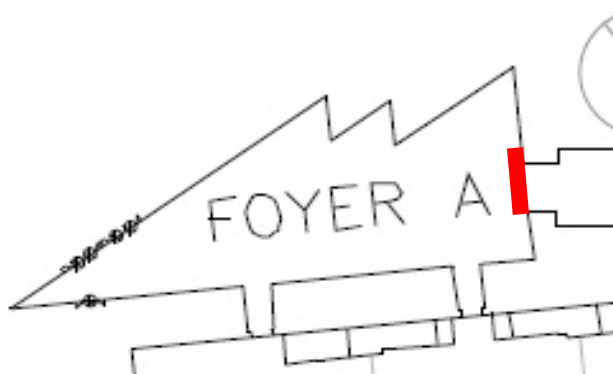
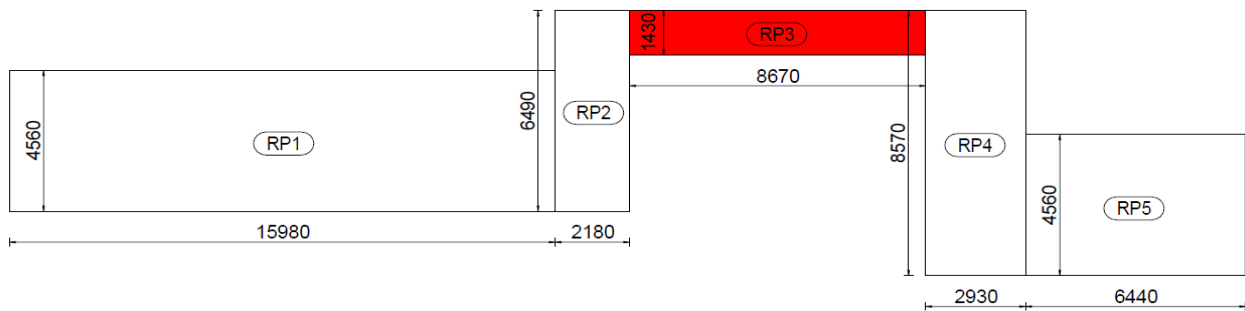
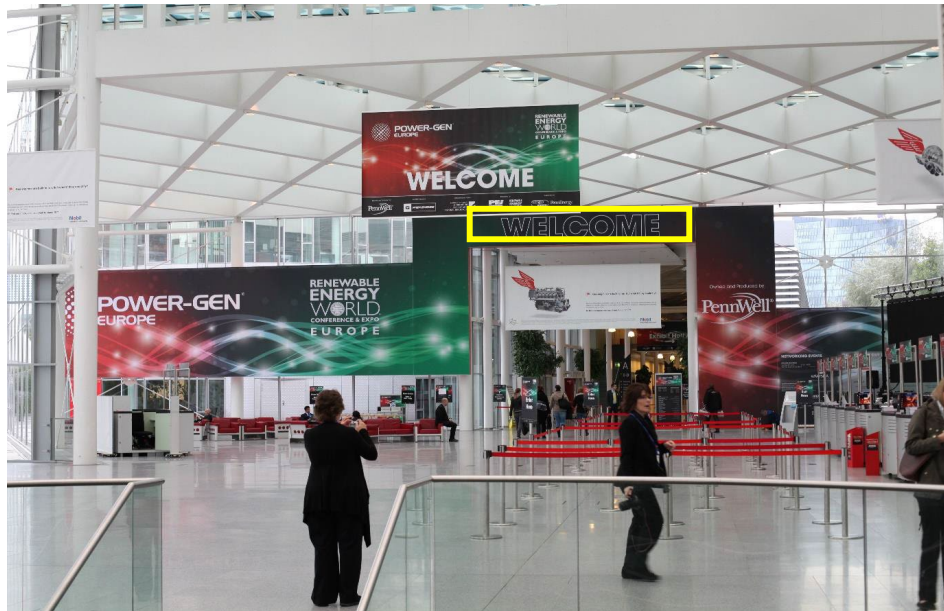

**CODE: RP4**

Position	<b>red frame branding - portal on the way to the mall Foyer A</b>		
Dimension (WxH)	2.930 mm	8.570 mm	
Visible Area (WxH)	2.930 mm	8.570 mm	
Sides	single sided		
Material	fabric material		
Total pieces	1		

Unit Price 3.058,70 €

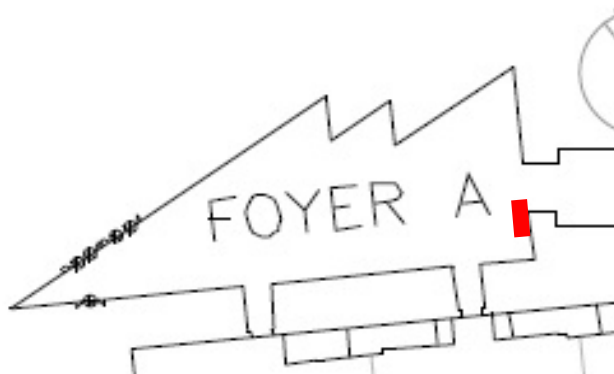
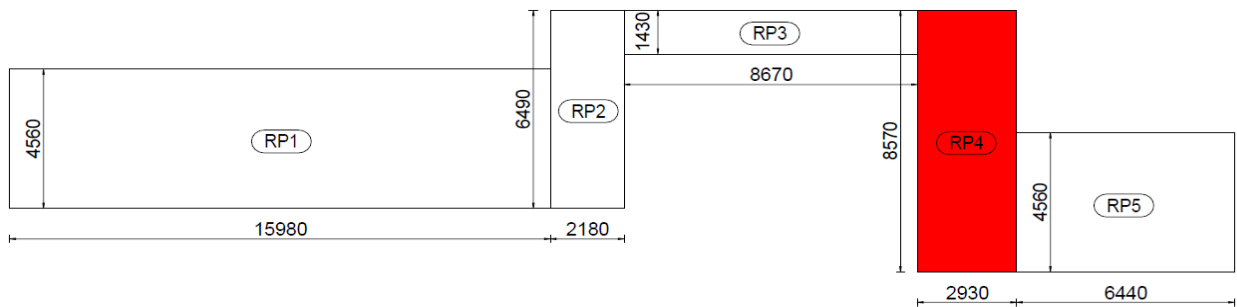
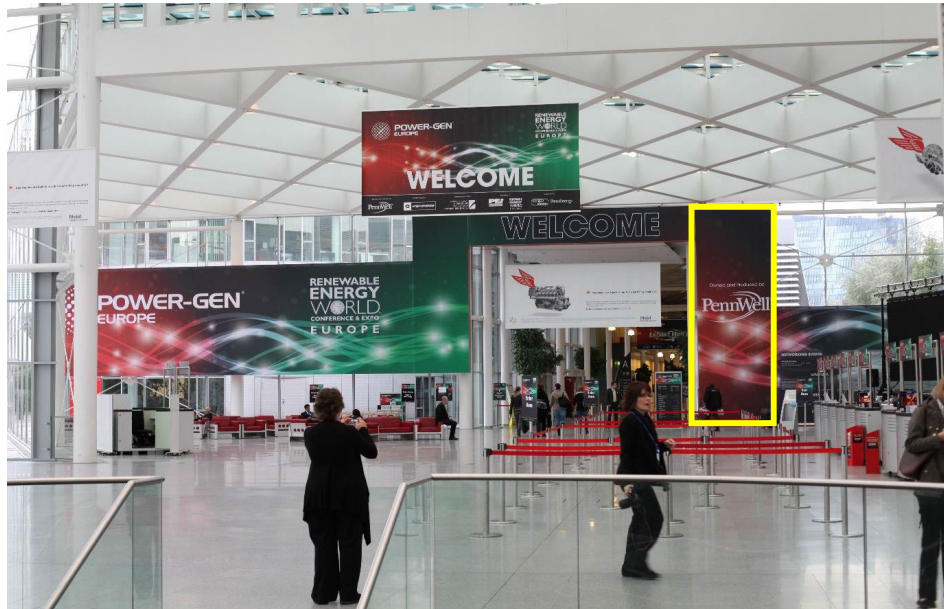

**CODE: RP5**

Position	<b>red frame branding - portal on the way to the mall Foyer A</b>		
Dimension (WxH)	6.440 mm	4.560 mm	
Visible Area (WxH)	6.440 mm	4.560 mm	
Sides	single sided		
Material	fabric material		
Total pieces	1		

Unit Price 3.569,50 €

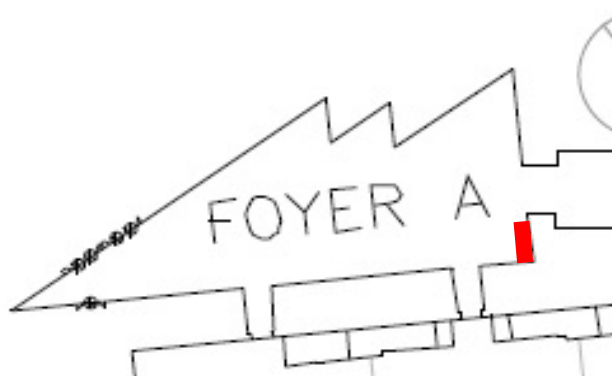
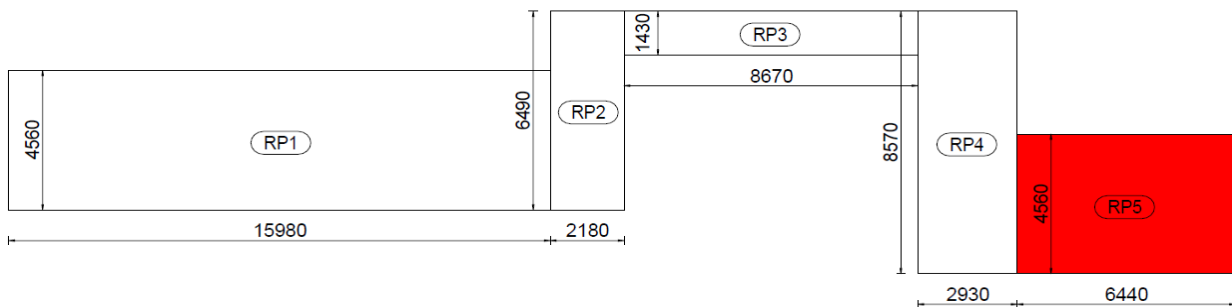
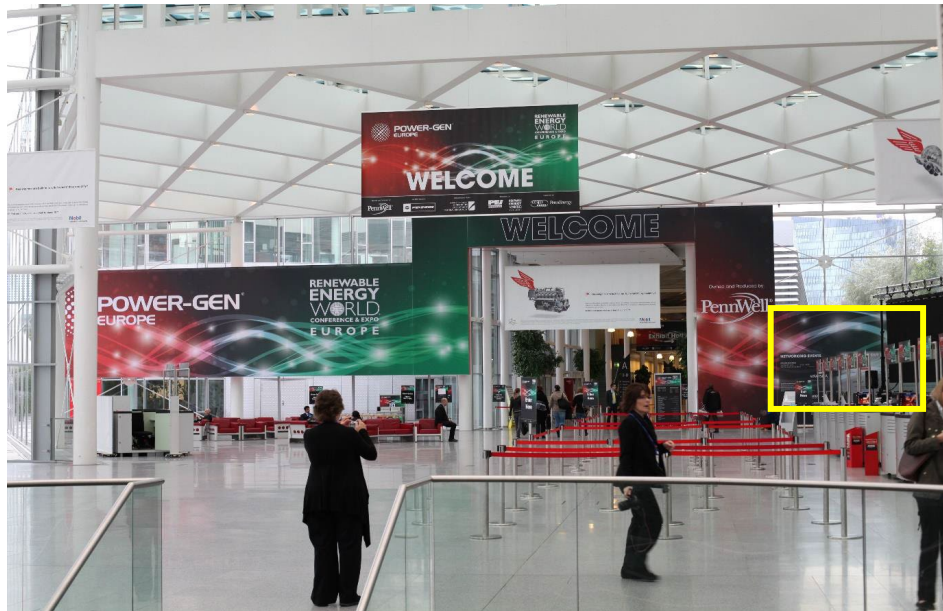

**CODE: MB1**

Position		Welcome-banner Foyer A to Mall	
Dimension (WxH)		6 500 mm	3 000 mm
Visible Area (WxH)		6 500 mm	3 000 mm
Sides		double sided	
Material		PVC	
Total pieces		1	

Unit Price 1 517,90 €

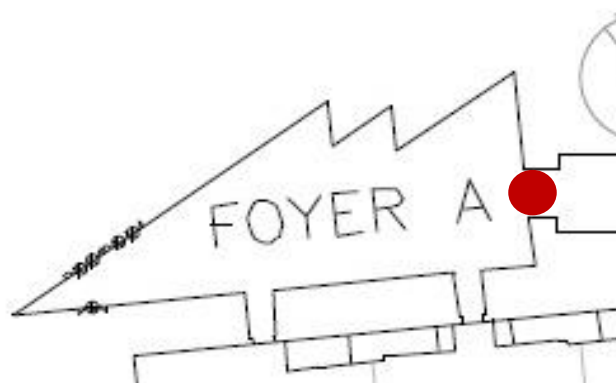
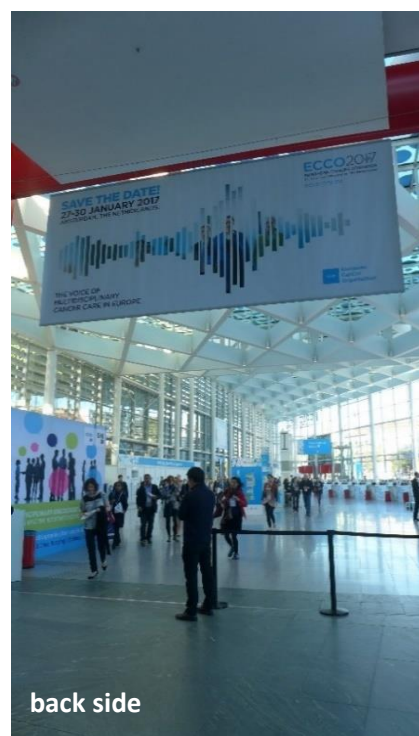

# STAND<sup>OUT</sup>

be visible



## SIGNAGE MALL

---

2026



# EXHIBITION CENTER

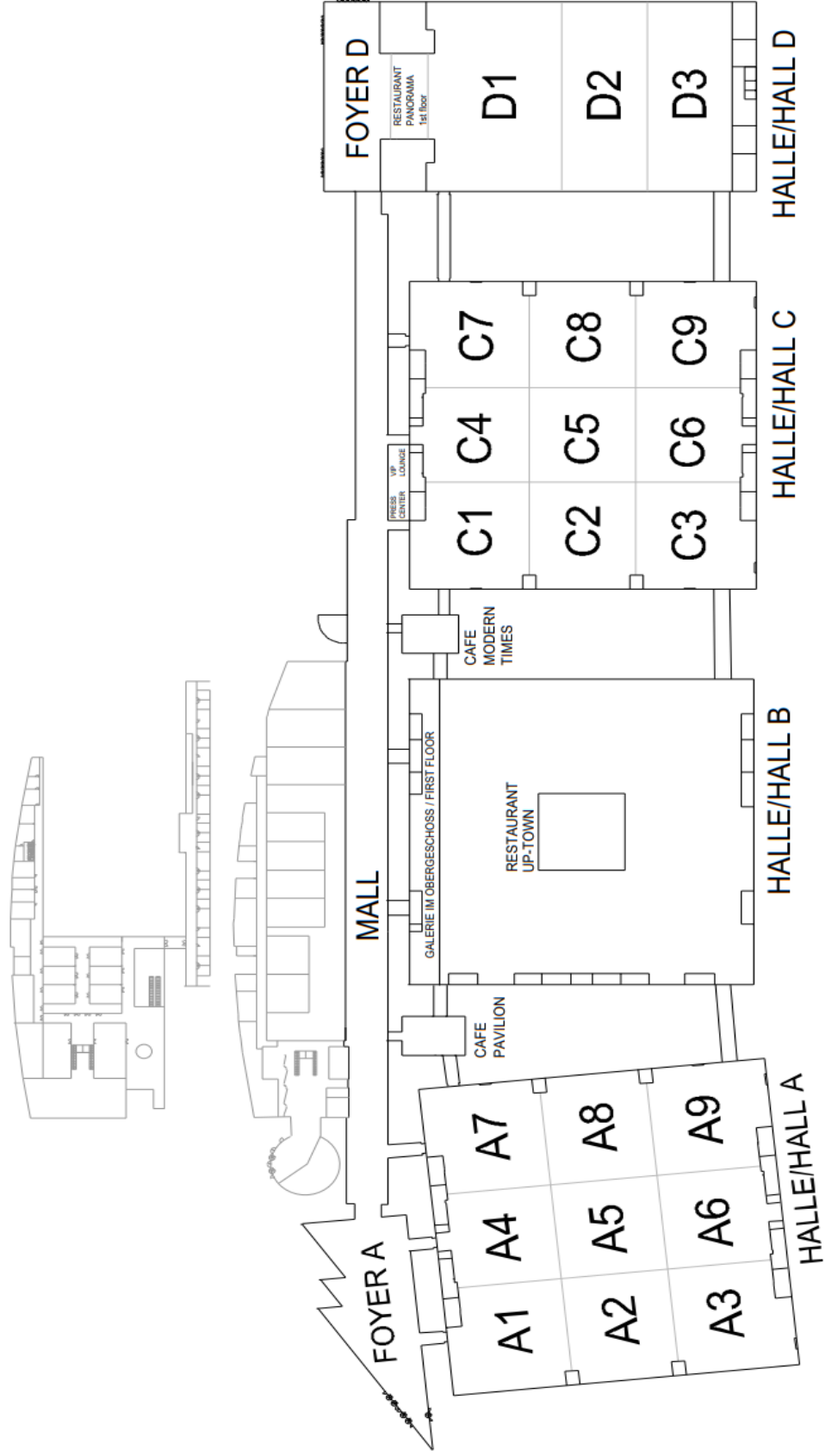

**CODE: ES1**

Position		branding on escalator-sides Mall	
Dimension (WxH)		8 818 mm	670 mm
Visible Area (WxH)		8 818 mm	670 mm
Sides		single	
Material		self adhesive foil	
Total pieces		8	

Unit Price 1 039,90 €

Price Total 8 319,20 €

outside elevation

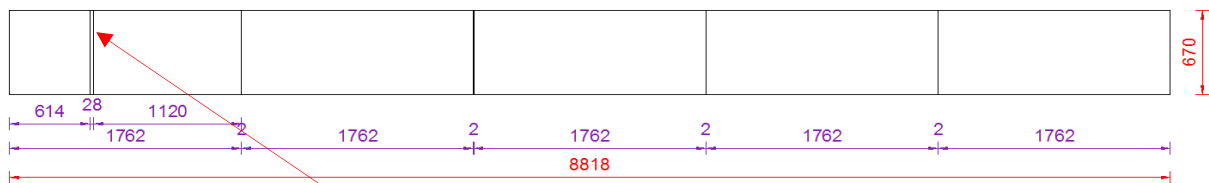

inside elevation

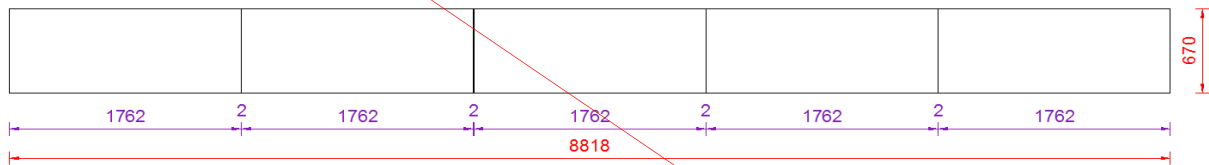

4 stretches on the inside  
4 stretches on the outside

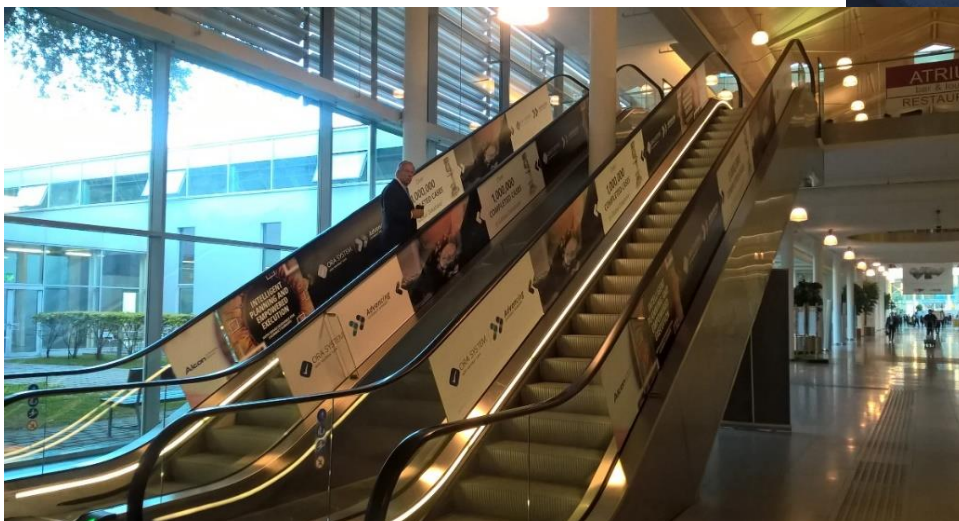

**CODE: SC1**

Position	<b>staircase branding Mall - riser</b>		
Dimension (WxH)	1 500 mm	120 mm	
Visible Area (WxH)	1 500 mm	120 mm	
Sides	single		
Material	self adhesive foil		
Total pieces	62 (31 left, 31 right)		

Unit Price 23,10 €

Price Total 1 432,20 €

foil on vertical part  
of the steps

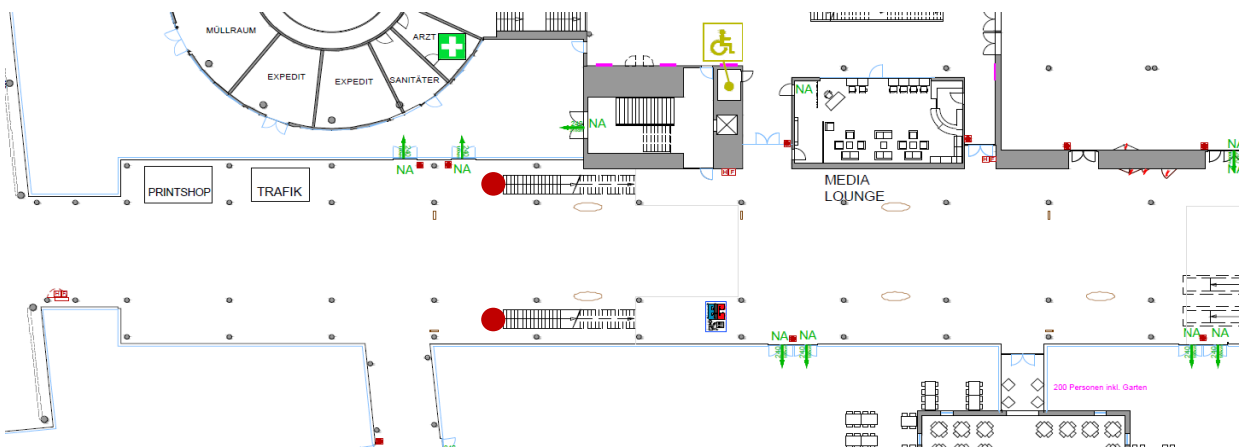

**CODE: SC2**

Position	<b>staircase branding Mall - tread</b>		
Dimension (WxH)	1 500 mm	1 545 mm	
Visible Area (WxH)	1 500 mm	1 545 mm	
Sides	single		
Material	self adhesive foil		
Total pieces	2 (1 left, 1 right)		

Unit Price 239,60 €

Price Total 479,20 €

foil on horizontal part of the big steps

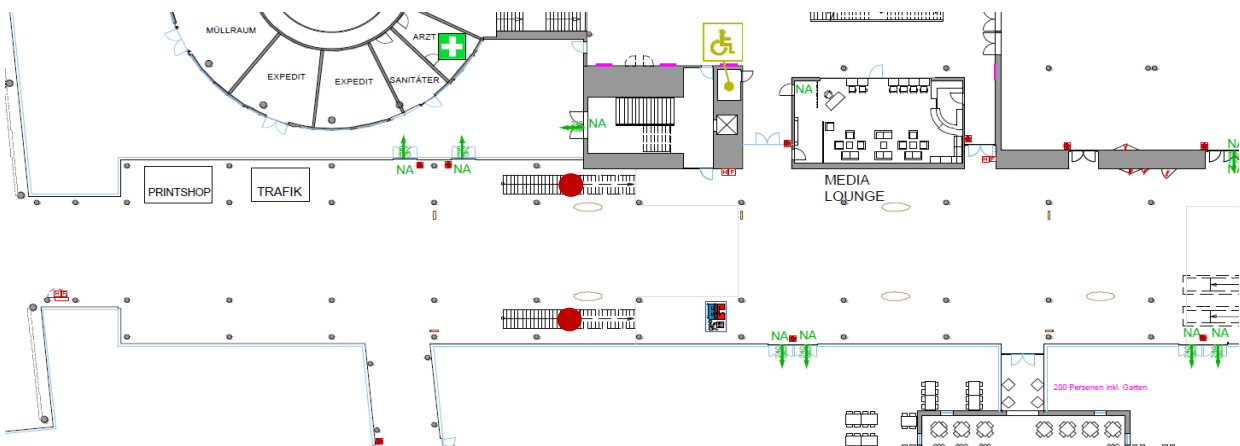
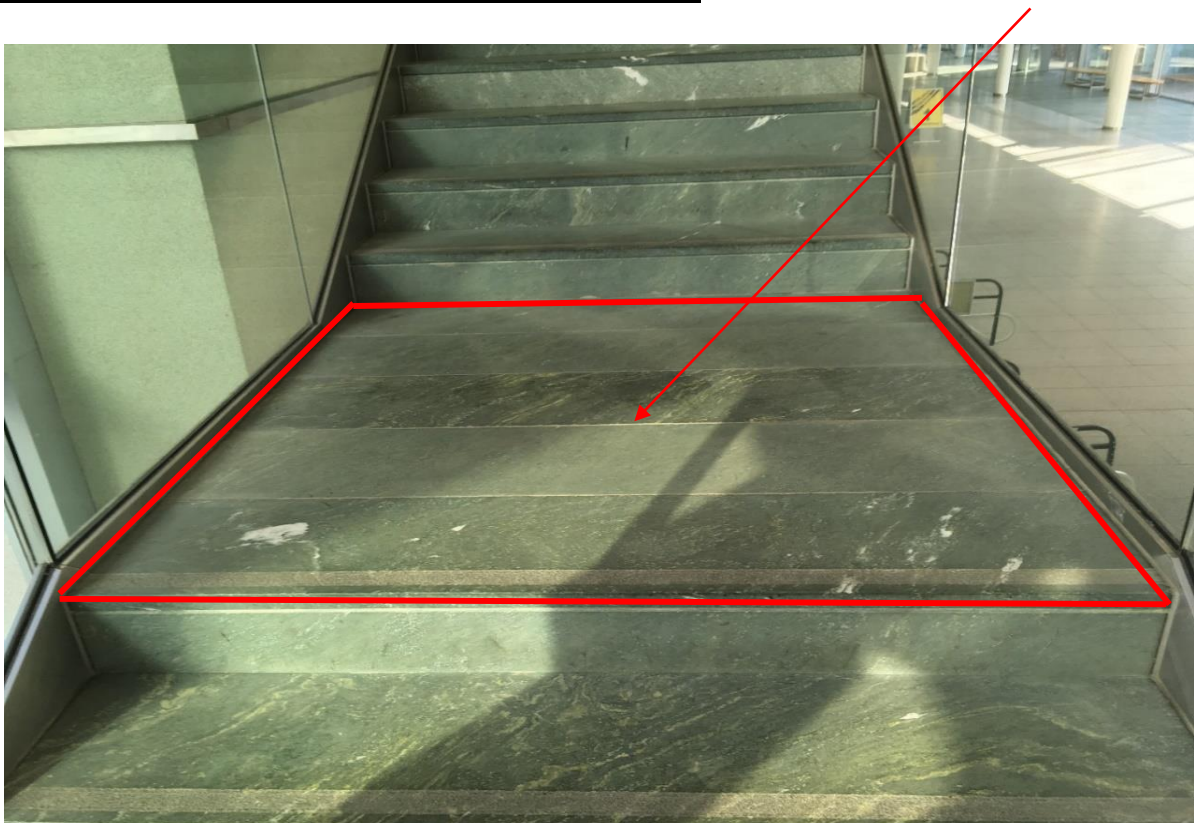

**CODE: SC3**

Position	<b>staircase branding Mall - lateral</b>		
Dimension (WxH)	-	-	please see sketch for measurements
Visible Area (WxH)	-	-	
Sides	single		
Material	self adhesive foil		
Total pieces	2 (1 left, 1 right)		

Unit Price 1 235,90 €

Price Total 2 471,80 €

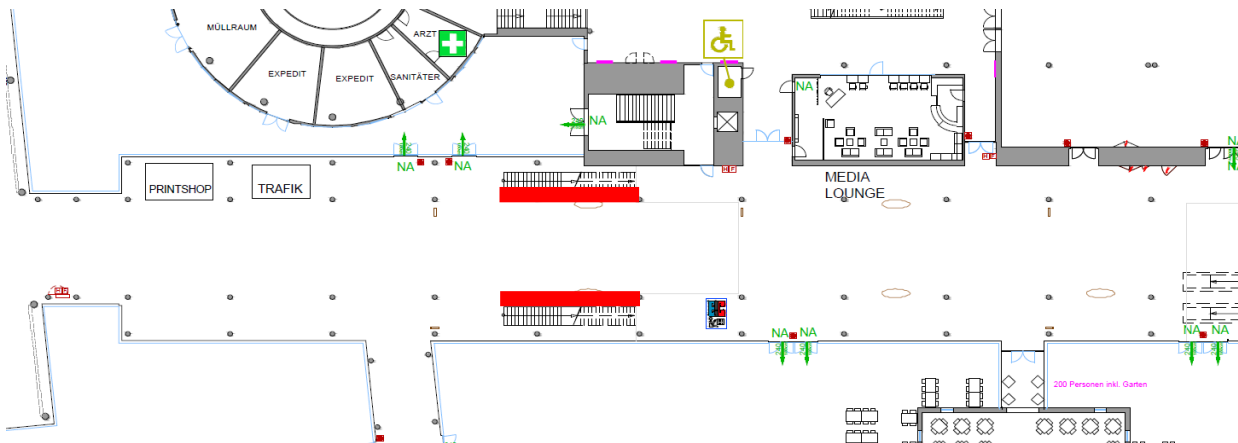

**CODE: SC3**

Position	<b>staircase branding Mall - lateral</b>		
Dimension (WxH)	-	-	please see sketch for measurements
Visible Area (WxH)	-	-	
Sides	single		
Material	self adhesive foil		
Total pieces	2 (1 left, 1 right)		

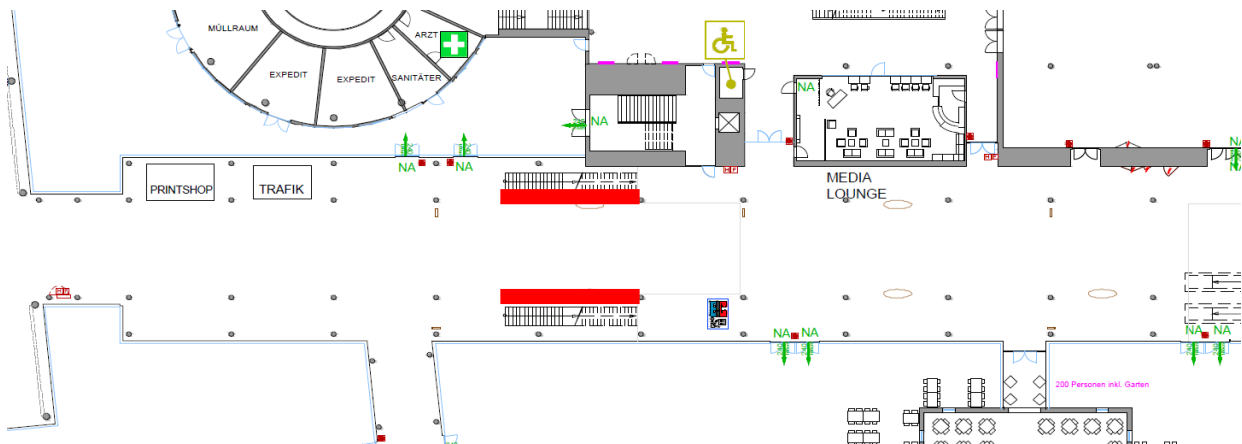
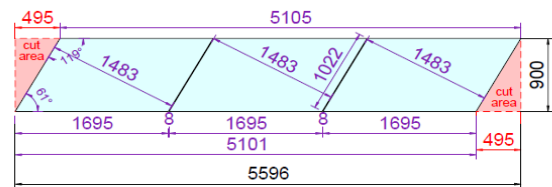
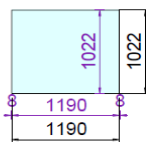
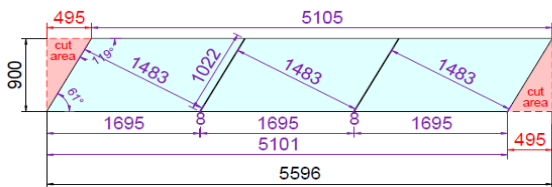
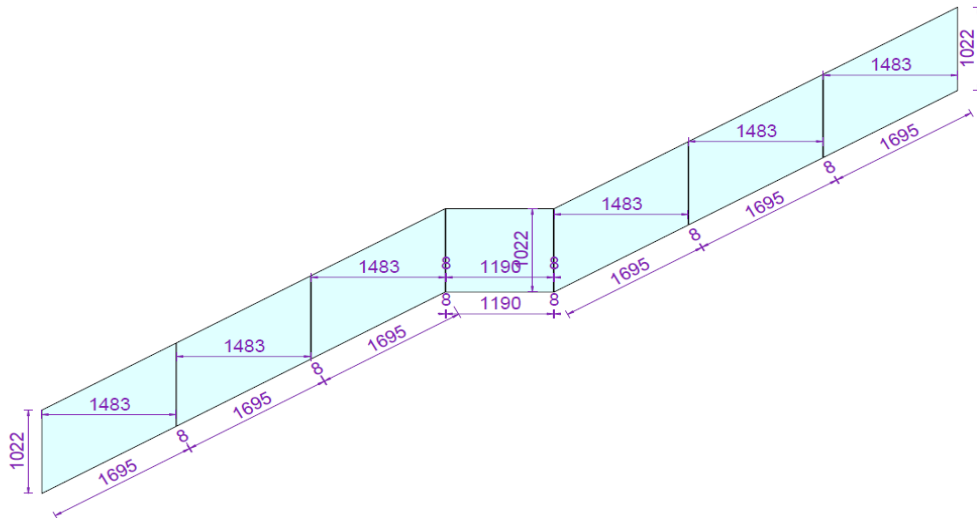

**CODE: MT1**

Position	<b>M10, 12, 13, 15, 17, 19, 21, 22, 24, 27- signage on totem in mall</b>		
Dimension (WxH)	695 mm	3 860 mm	
Visible Area (WxH)	695 mm	3 860 mm	
Sides	double sided		
Material	forex, 3mm		
Total pieces	10		

Unit Price (per side) 220,20 €

Price Total (1 complete totem) 440,40 €

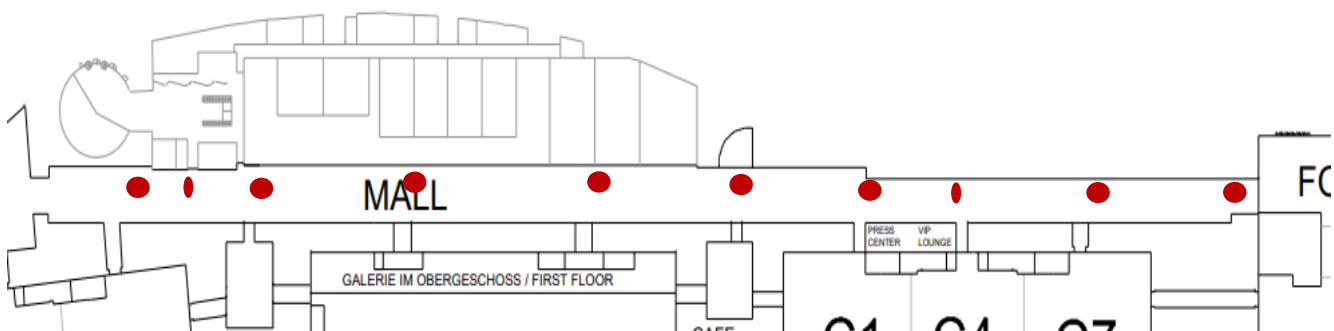
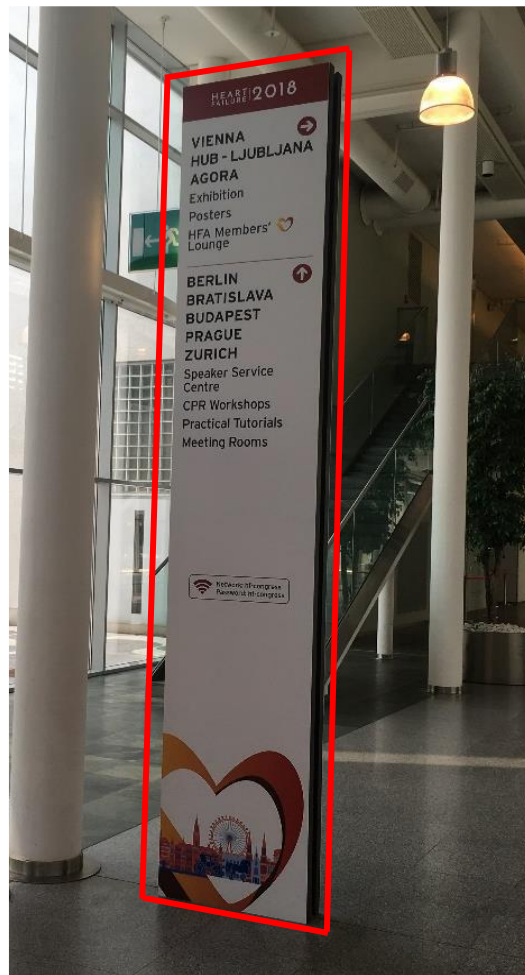

**CODE: MT2**

Position	<b>M11, 14, 16, 18, 20, 26 signage on totem single-sided in Mall</b>		
Dimension (WxH)	695 mm	3 860 mm	
Visible Area (WxH)	695 mm	3 860 mm	
Sides	single sided		
Material	forex, 3mm		
Total pieces	6		

Unit Price 220,20 €

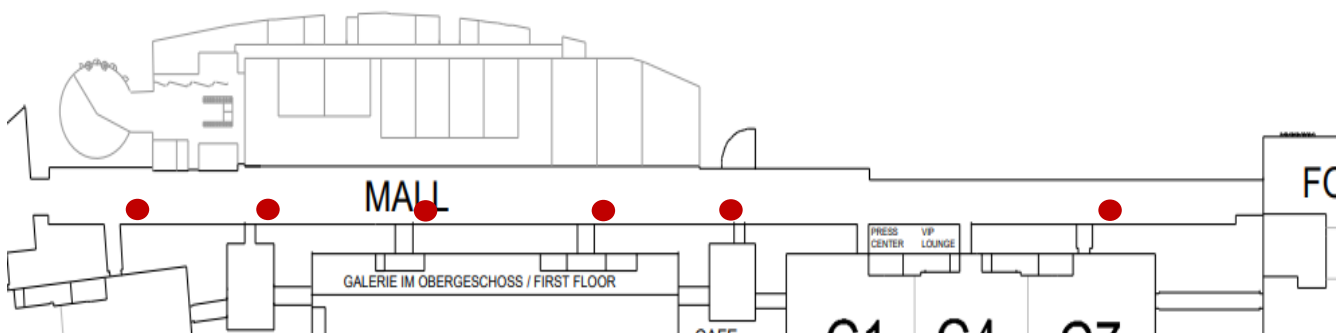

**CODE: M1**

Position	<b>signage on overhead signpost above entrance to Hall A</b>		
Dimension (WxH)	5 830 mm	680 mm	
Visible Area (WxH)	5 830 mm	680 mm	
Sides	single sided		
Material	graphic fabric		
Total pieces	1		

Unit Price 592,80 €

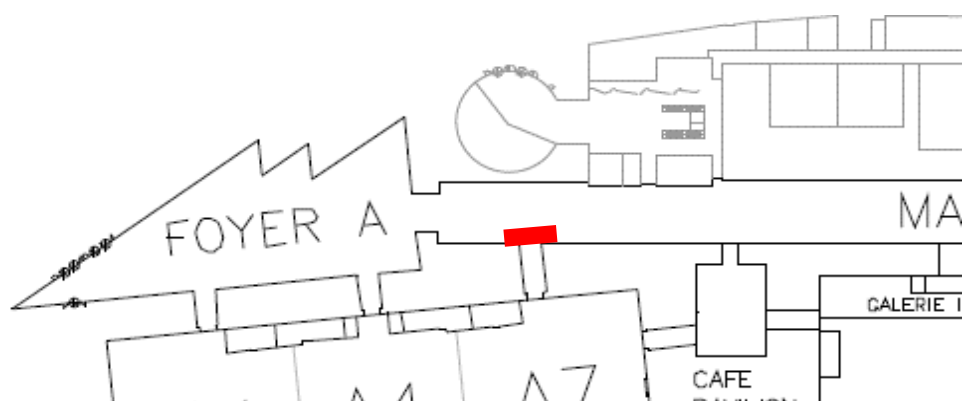

**CODE: M3 / M4**

Position	<b>signage on overhead signpost above entrance to Hall B</b>		
Dimension (WxH)	6 420 mm	600 mm	
Visible Area (WxH)	6 420 mm	600 mm	
Sides	single sided		
Material	graphic fabric		
Total pieces	2		

Unit Price 602,50 €



**CODE: M6 / M7**

Position	<b>signage on overhead signpost above entrance to Hall C</b>		
Dimension (WxH)	3 300 mm	600 mm	
Visible Area (WxH)	3 300 mm	600 mm	
Sides	single sided		
Material	graphic fabric		
Total pieces	2		

Unit Price 352,00 €

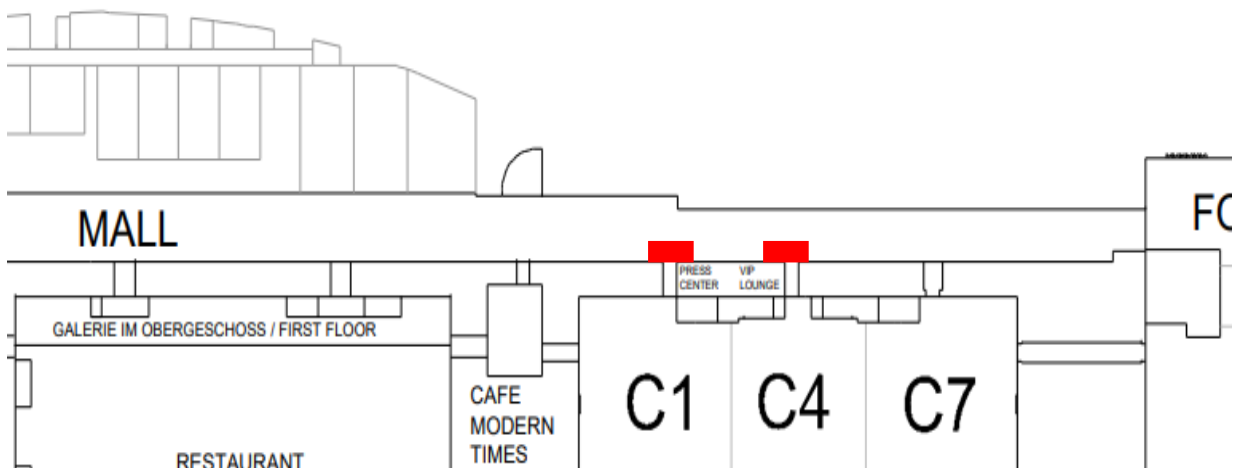

**CODE: M8**

Position	<b>signage on overhead signpost above entrance to Hall C</b>		
Dimension (WxH)	5 510 mm	600 mm	
Visible Area (WxH)	5 510 mm	600 mm	
Sides	single sided		
Material	graphic fabric		
Total pieces	1		

Unit Price 570,20 €

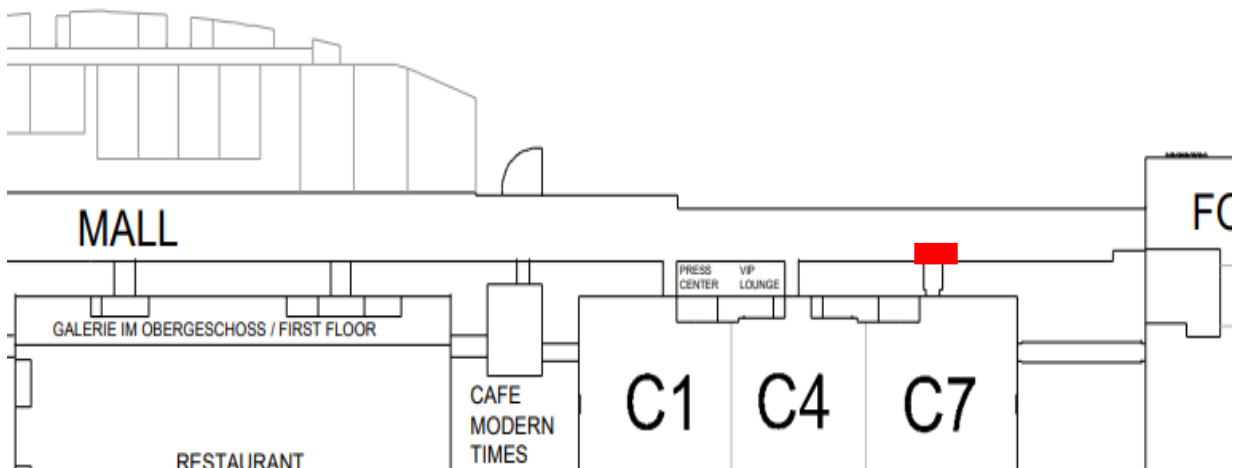

**CODE: MB2**

Position	<b>suspended mall-banner double-side printed</b>		
Dimension (WxH)	1 400 mm	4 000 mm	
Visible Area (WxH)	1 400 mm	4 000 mm	
Sides	double sided		
Material	PVC		
Total pieces	several		

Unit Price 588,90 €

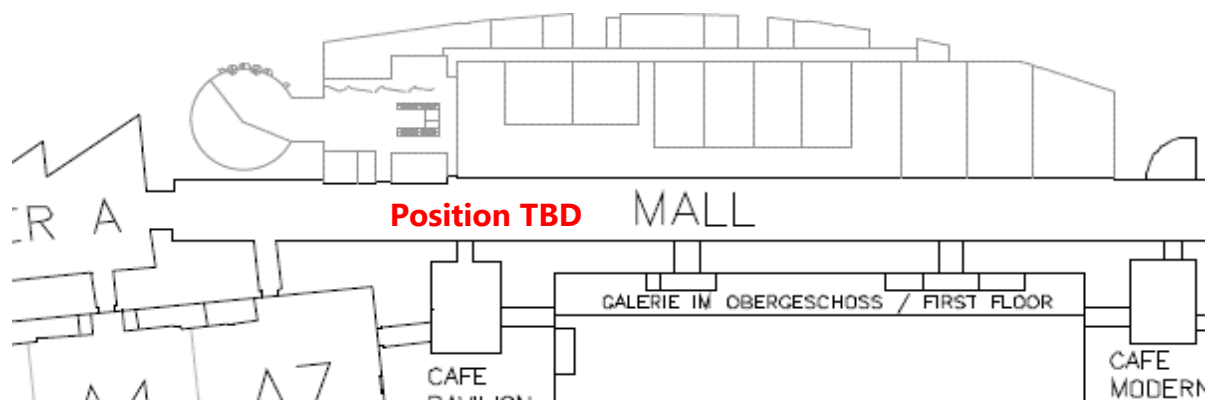
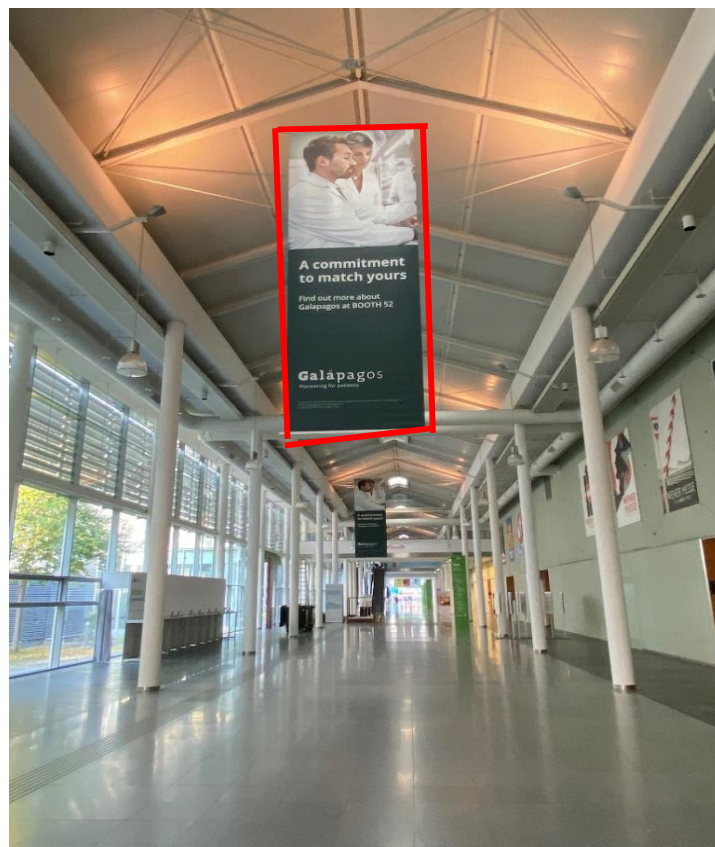

**CODE: MB3**

Position	<b>Mall banner double-sided</b>		
Dimension (WxH)	4 000 mm	4 000 mm	
Visible Area (WxH)	4 000 mm	4 000 mm	
Sides	double sided		
Material	PVC		
Total pieces	several		

Unit Price 1 301,80 €

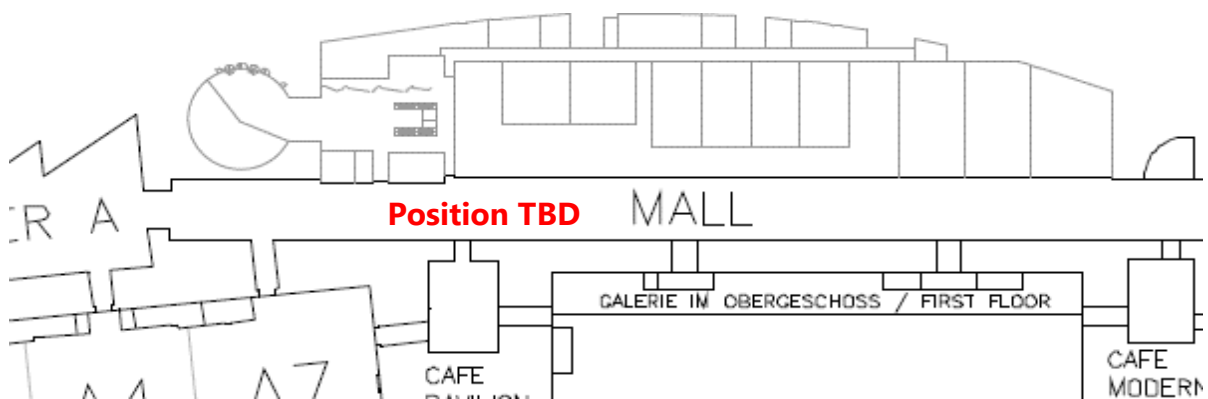
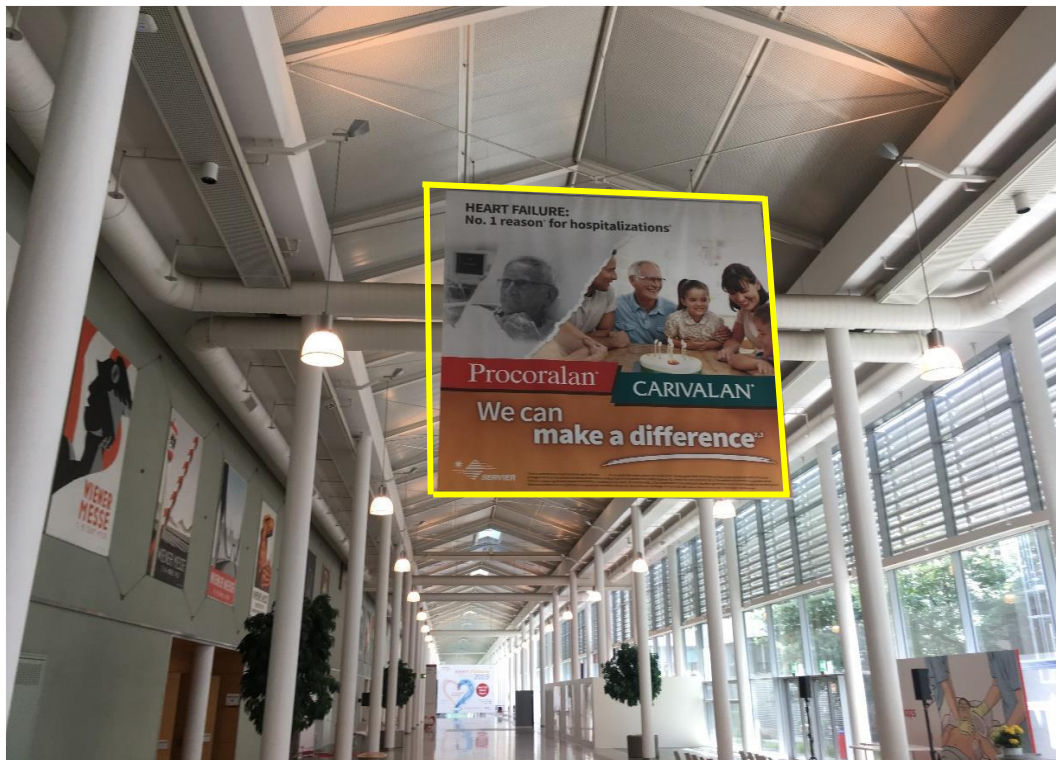

**CODE: BA1**

Position	<b>bridge banner Atrium seen from Foyer A, Mall</b>		
Dimension (WxH)	7 300 mm	1 020 mm	
Visible Area (WxH)	7 300 mm	1 020 mm	
Sides	single sided (backside covered white)		
Material	foam board, 5mm		
Total pieces	1		

Unit Price 1 077,30 €

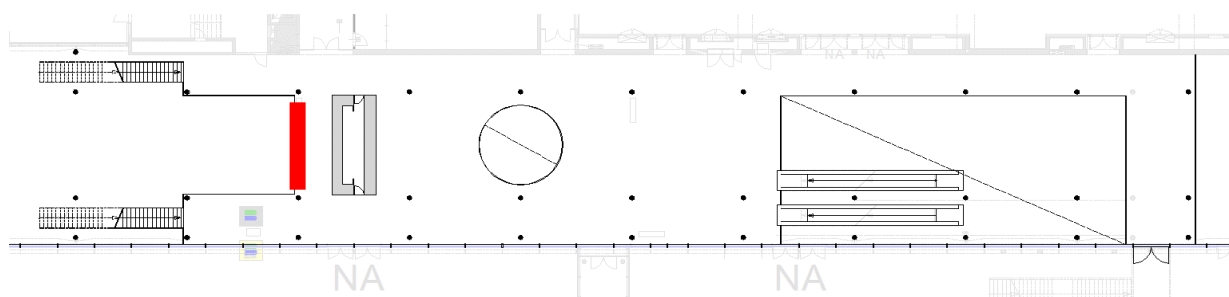

**CODE: BA2**

Position	<b>bridge banner Atrium seen from Hall C, Mall</b>		
Dimension (WxH)	5 500 mm	1 020 mm	
Visible Area (WxH)	5 500 mm	1 020 mm	
Sides	single sided (backside covered white)		
Material	foam board, 5mm		
Total pieces	1		

Unit Price 728,80 €

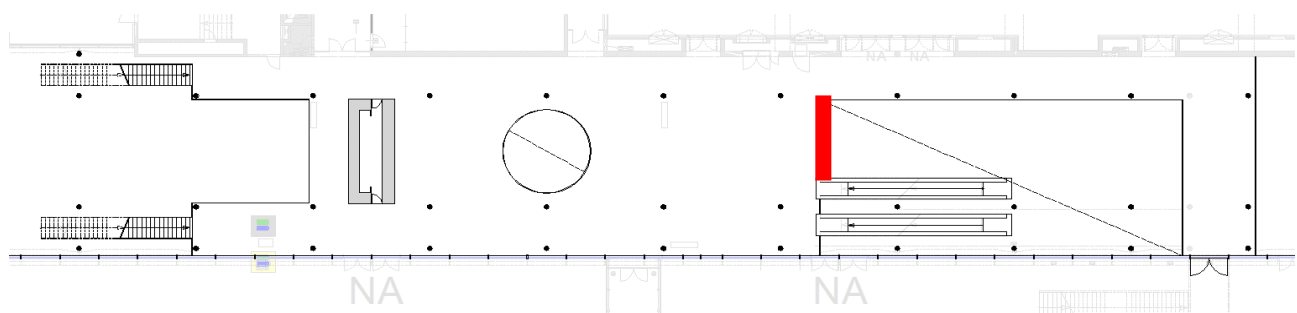

**CODE: BB1**

Position	<b>bridge banner gallery seen from Foyer A, Mall</b>		
Dimension (WxH)	11 160 mm	1 020 mm	
Visible Area (WxH)	11 160 mm	1 020 mm	
Sides	single sided (backside covered white)		
Material	foam board, 5mm		
Total pieces	1		

Unit Price 1 368,40 €

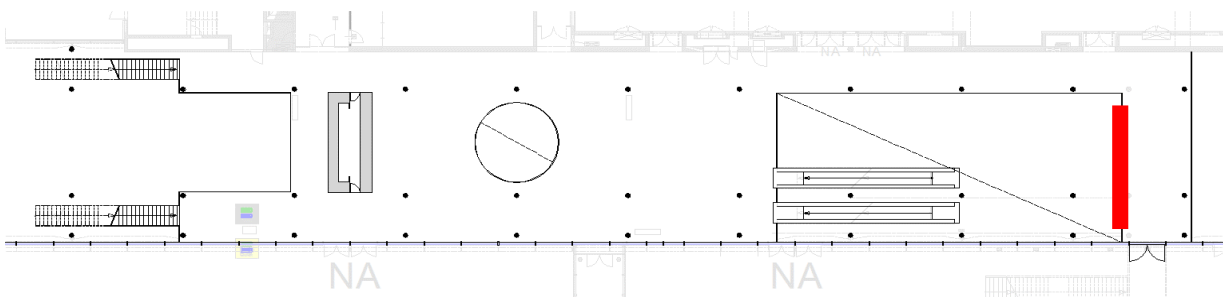

**CODE: BB2**

Position	<b>bridge banner gallery seen from Hall C, Mall</b>		
Dimension (WxH)	14 300 mm	1 020 mm	
Visible Area (WxH)	14 300 mm	1 020 mm	
Sides	single side (backside covered white)		
Material	foam board, 5mm		
Total pieces	1		

Unit Price 1 454,50 €

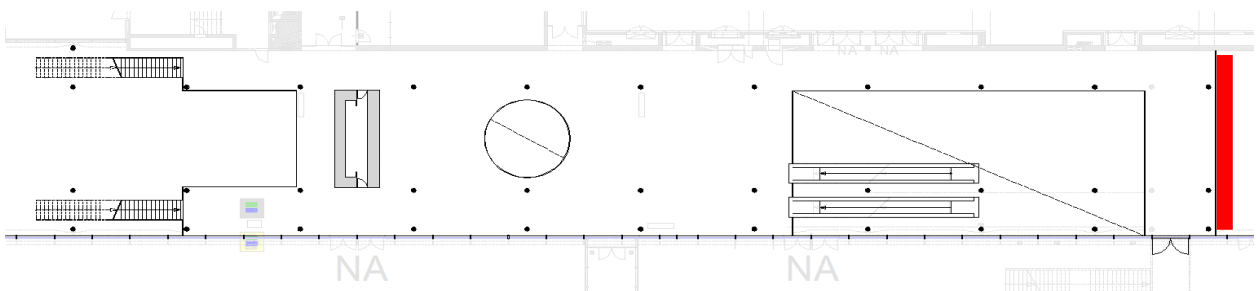

**CODE: M29**

Position		signage doors entrances to MCC (16 pcs)	
Dimension	(WxH)	300 mm	300 mm
Visible Area	(WxH)	300 mm	300 mm
Sides		single sided	
Material		forex, 3mm	
Total pieces		16	

Unit Price 33,50 €



**CODE: MC1**

Position	<b>sign above MCC Room entrances, Mall</b>		
Dimension (WxH)	2 000 mm	450 mm	
Visible Area (WxH)	2 000 mm	450 mm	
Sides	single sided		
Material	foam board, 5mm		
Total pieces	11		

Unit Price 112,90 €



**CODE: GD1**

Position	<b>signage on glass doors leading to bridge MCC</b>		
Dimension (WxH)	1 100 mm	500 mm	
Visible Area (WxH)	1 100 mm	500 mm	
Sides	single		
Material	self adhesive foil		
Total pieces	2		

Unit Price 66,60 €

Total price 133,20 €

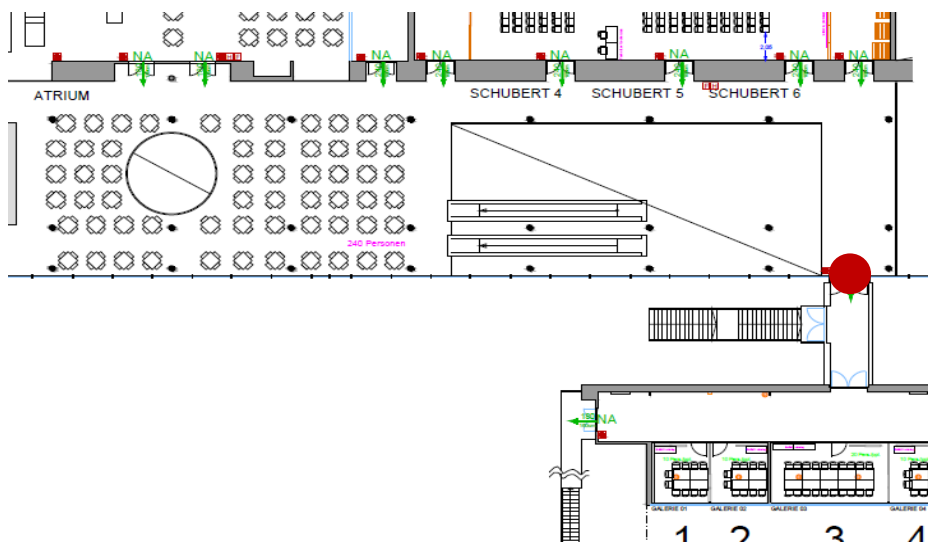

**CODE: M9**

Position	<b>signage on overhead signpost above entrance to Foyer D</b>		
Dimension (WxH)	4 500 mm	2 550 mm	(H max=4300mm)
Visible Area (WxH)	4 500 mm	2 550 mm	(H max=4300mm)
Sides	single sided		
Material	graphic fabric		
Total pieces	1		

Unit Price 863,20 €

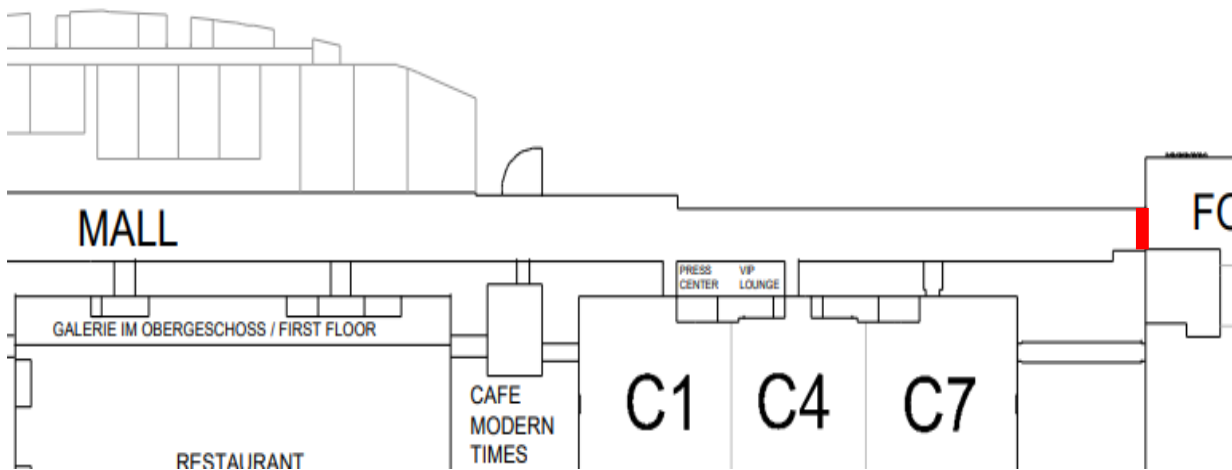

**CODE: MB4**

Position	<b>close off banner, Mall</b>		
Dimension (WxH)	6 000 mm	5 000 mm	
Visible Area (WxH)	6 000 mm	5 000 mm	
Sides	single sided		
Material	graphic fabric		
Total pieces	1		

Unit Price 1 635,60 €



# STAND<sup>OUT</sup>

be visible



## SIGNAGE HALLS

---

2026



# EXHIBITION CENTER

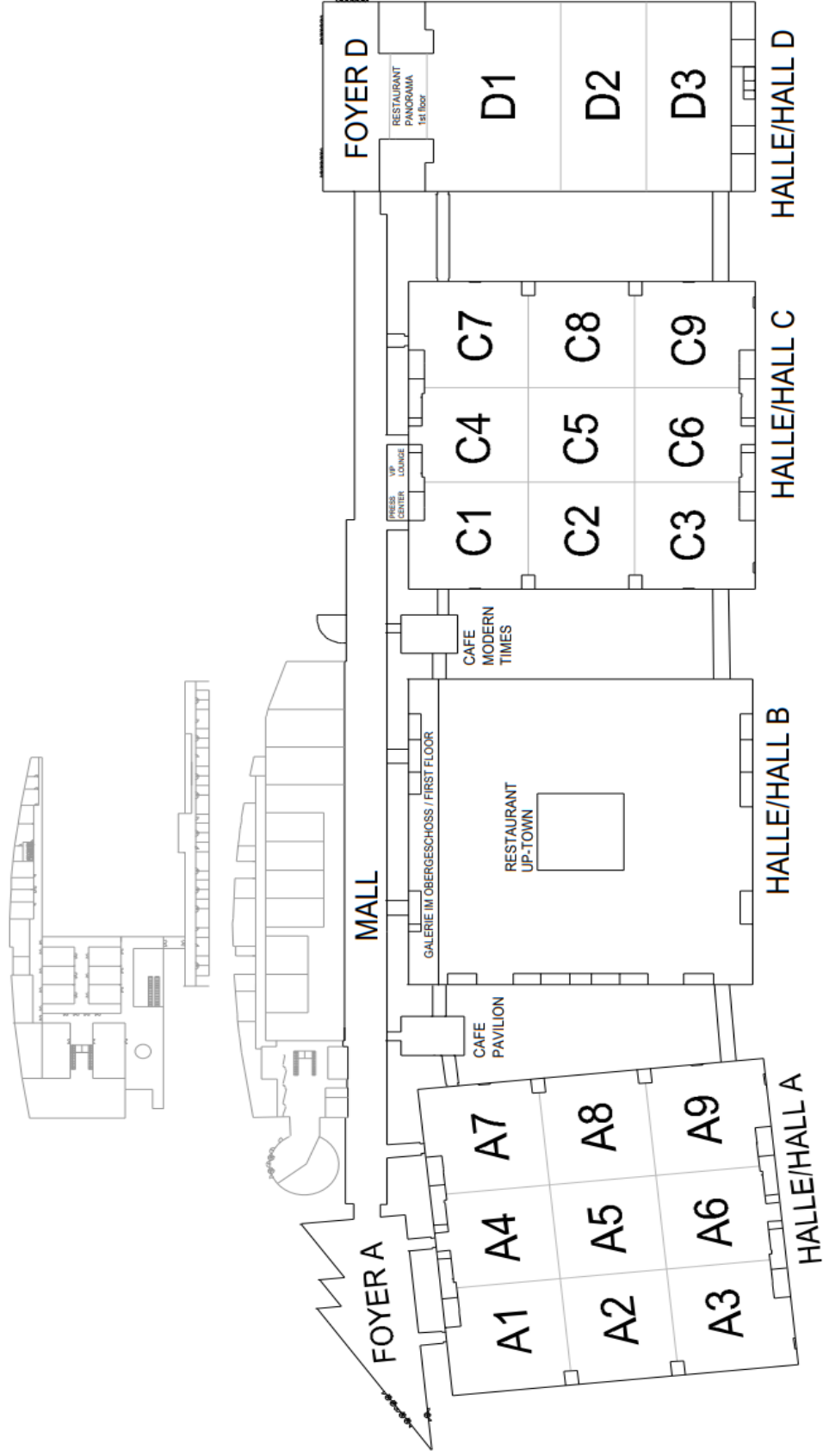

**CODE: A1-A9**

Position	<b>signage on overhead signpost above entrance to Foyer A</b>		
Dimension (WxH)	4 000 mm	1 900 mm	
Visible Area (WxH)	4 000 mm	1 900 mm	
Sides	single		
Material	frame with fabric covering		
Total pieces	9		

Unit Price 981,60 €

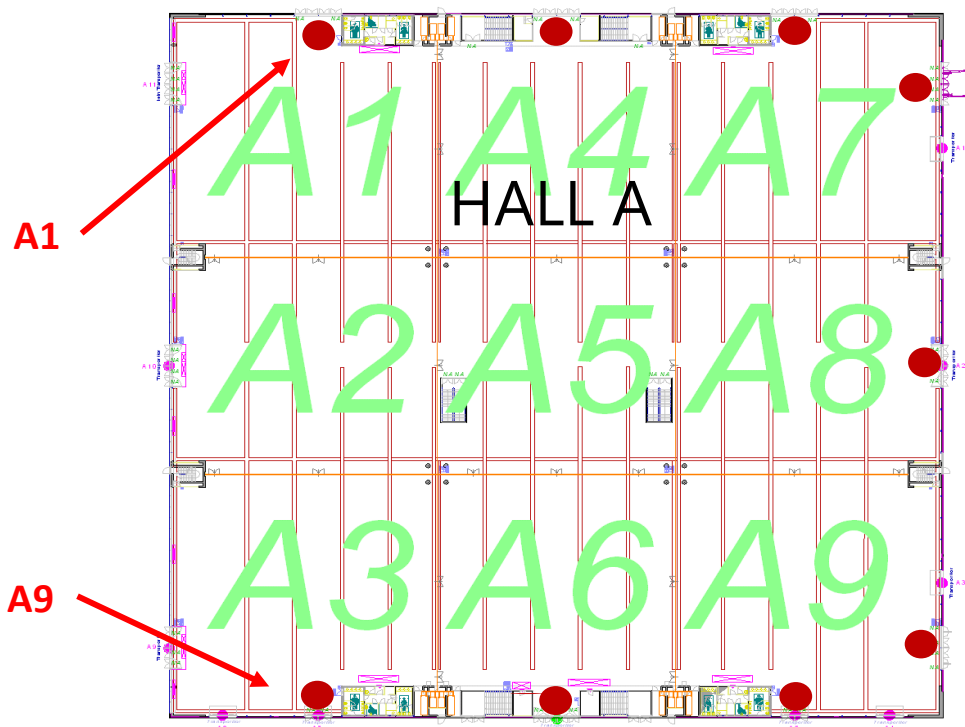

**CODE: B3-B8**

Position	<b>signage on overhead signpost above entrance to Hall C</b>		
Dimension (WxH)	4 000 mm	1 900 mm	
Visible Area (WxH)	4 000 mm	1 900 mm	
Sides	single		
Material	frame with fabric covering		
Total pieces	6		

Unit Price 981,60 €

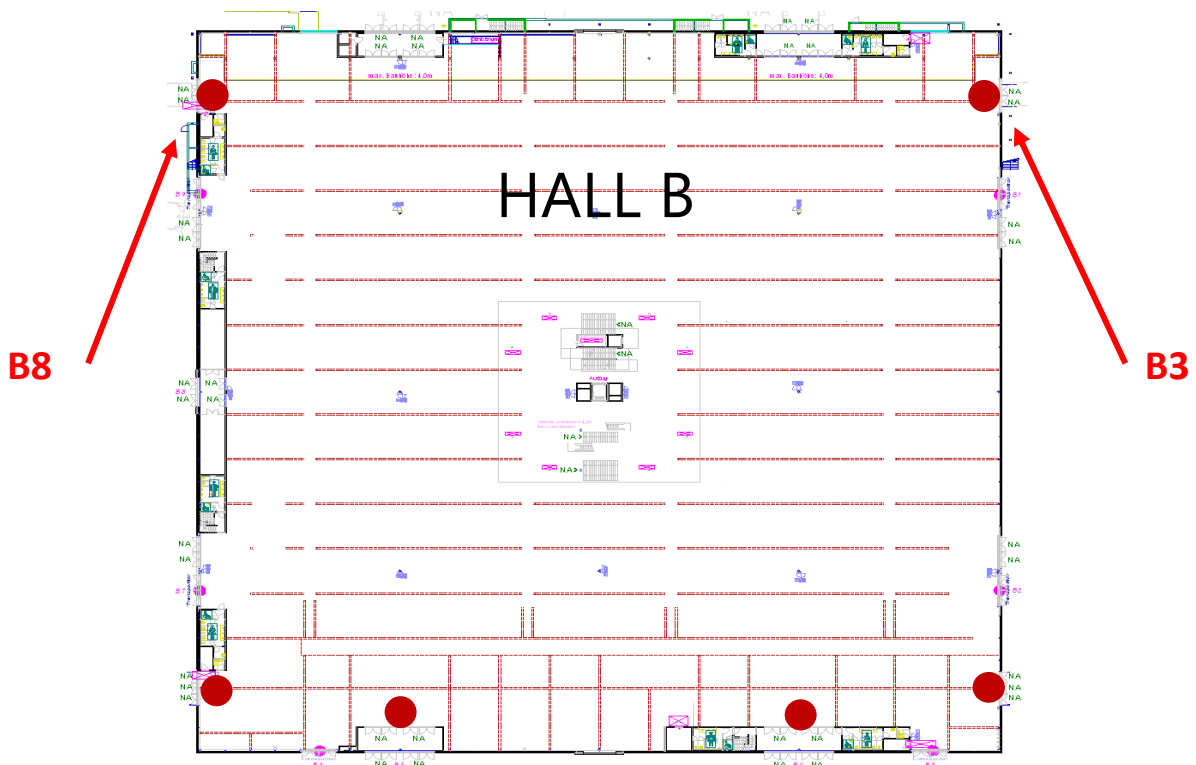

**CODE: GD2**

Position	<b>signage above door vis-a-vis Mall</b>		
Dimension (WxH)	2 407 mm	666 mm	
Visible Area (WxH)	2 407 mm	666 mm	
Sides	single side (backside covered white)		
Material	self adhesive foil		
Total pieces	4		

Unit Price 106,40 €

Price Total 425,60 €

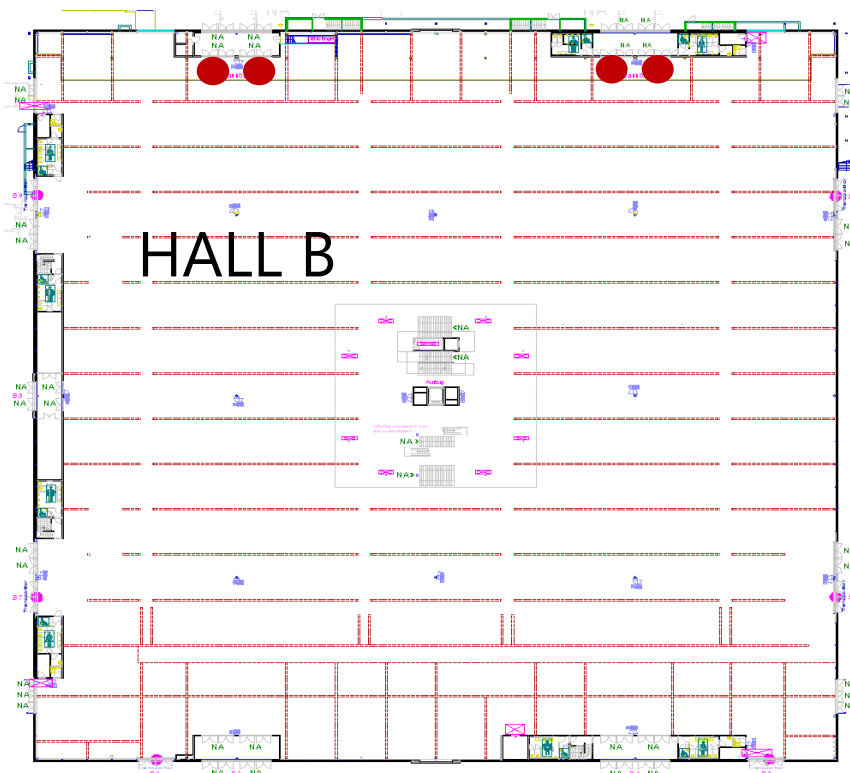

**CODE: AC1**

Position	<b>signage at the stairs to the Gallery rooms</b>		
Dimension (WxH)	900 mm	1 800 mm	
Visible Area (WxH)	900 mm	1 800 mm	
Sides	single		
Material	forex, 5mm		
Total pieces	1		

Unit Price 128,50 €

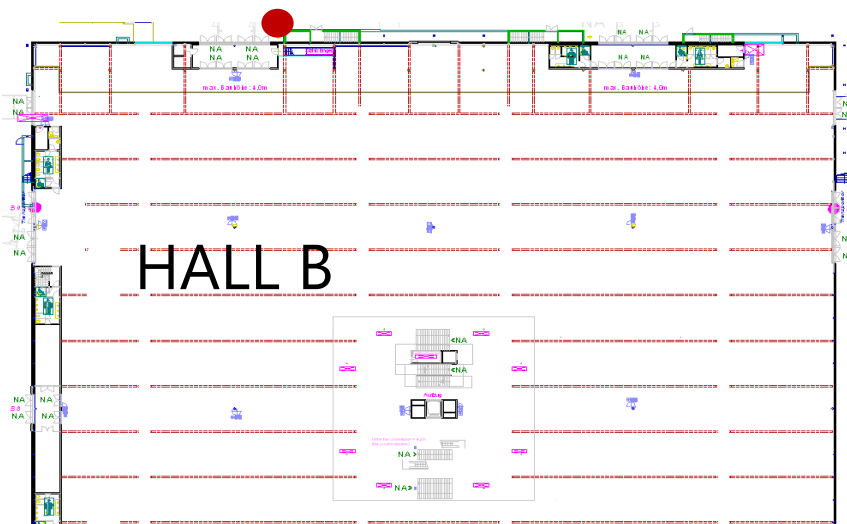
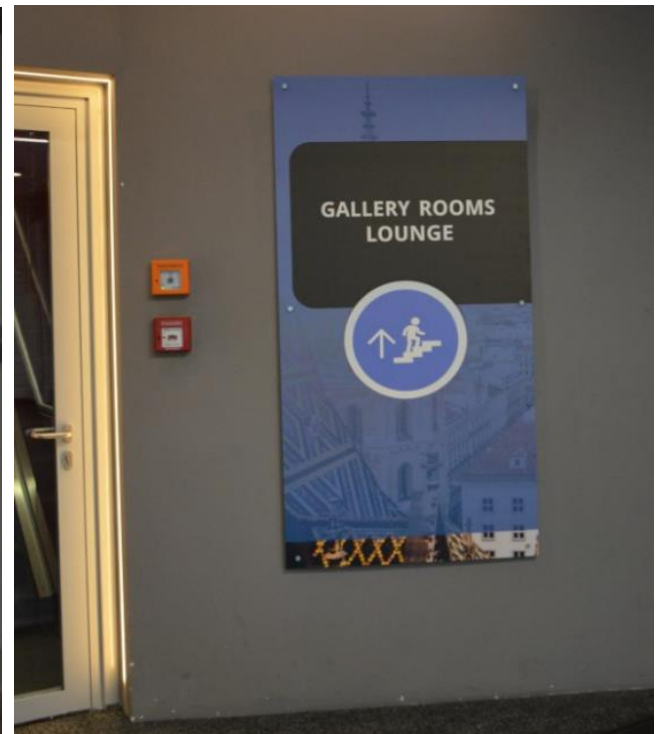

**CODE: C1-C12**

Position	<b>signage on overhead signpost above entrance to Mall</b>		
Dimension (WxH)	4 000 mm	1 900 mm	
Visible Area (WxH)	4 000 mm	1 900 mm	
Sides	single		
Material	frame with fabric covering		
Total pieces	12		

Unit Price 981,60 €



C1

C12

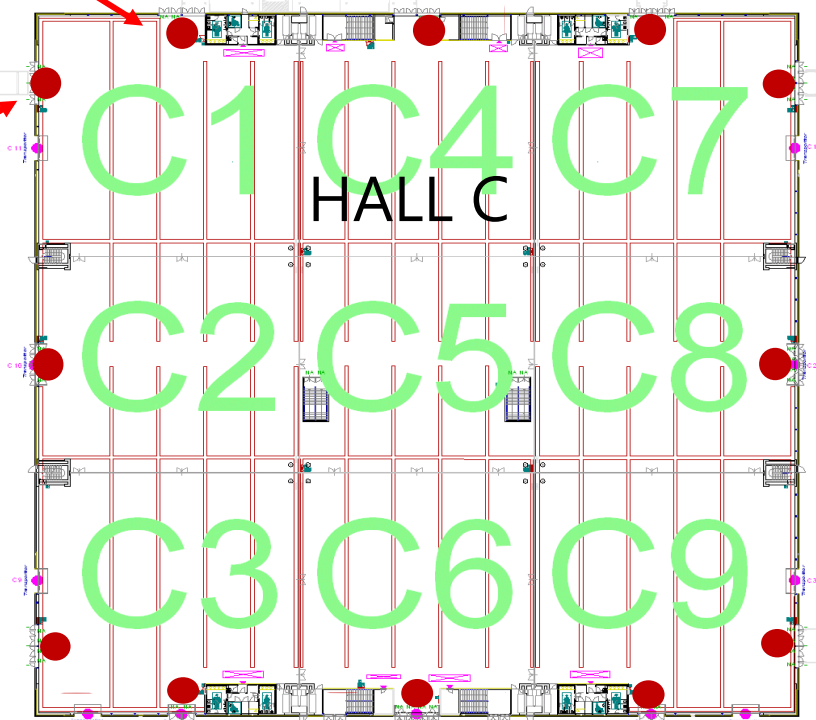

**CODE: D1 / D2**

Position	<b>signage on overhead signpost above entrance to Hall C</b>		
Dimension (WxH)	4 000 mm	1 900 mm	
Visible Area (WxH)	4 000 mm	1 900 mm	
Sides	single		
Material	frame with fabric covering		
Total pieces	2		

Unit Price 981,60 €

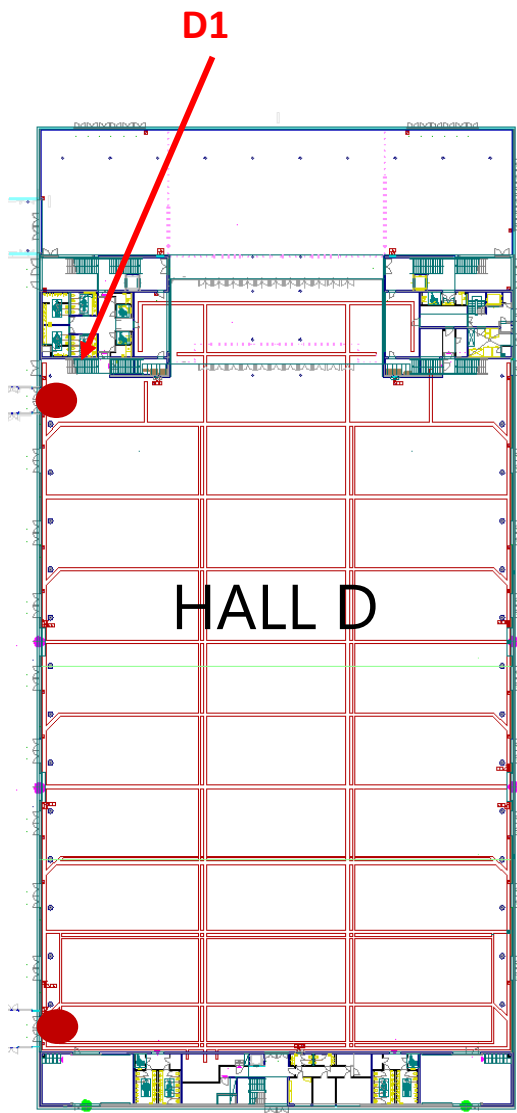

**CODE: CB1**

Position	<b>large catering banner</b>		
Dimension (WxH)	6 000 mm	2 500 mm	
Visible Area (WxH)	6 000 mm	2 500 mm	
Sides	single sided		
Material	graphic fabric		
Total pieces	1		

Unit Price 2 290,00 €



**CODE: PB1**

Position		Poster Banner	
Dimension	(WxH)	1 500 mm	3 500 mm
Visible Area	(WxH)	1 500 mm	3 500 mm
Sides		double sided	
Material		PVC	
Total pieces		1	

Unit Price 952,10 €



# STAND<sup>OUT</sup>

be visible

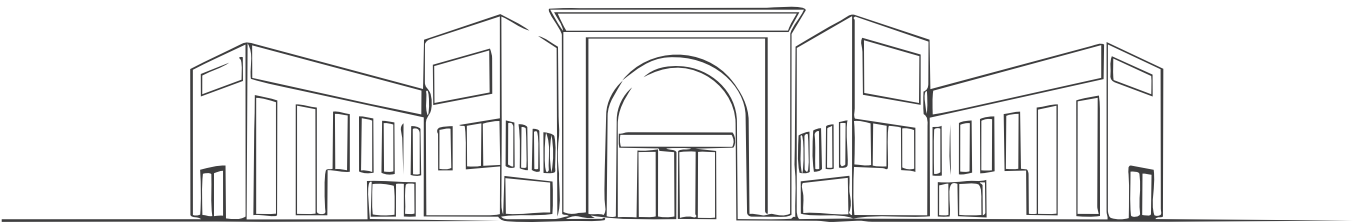

## SIGNAGE CONGRESS CENTER

---

2026



# CONGRESS CENTER

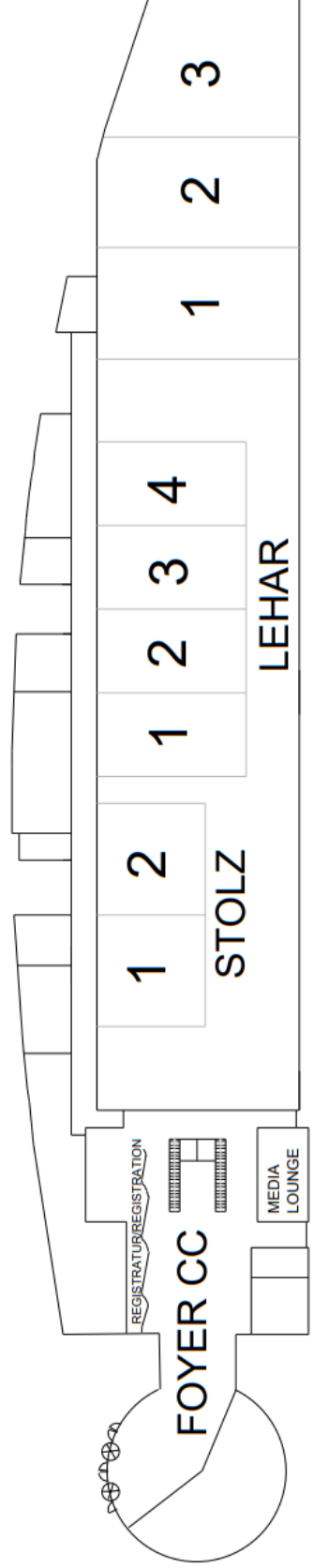
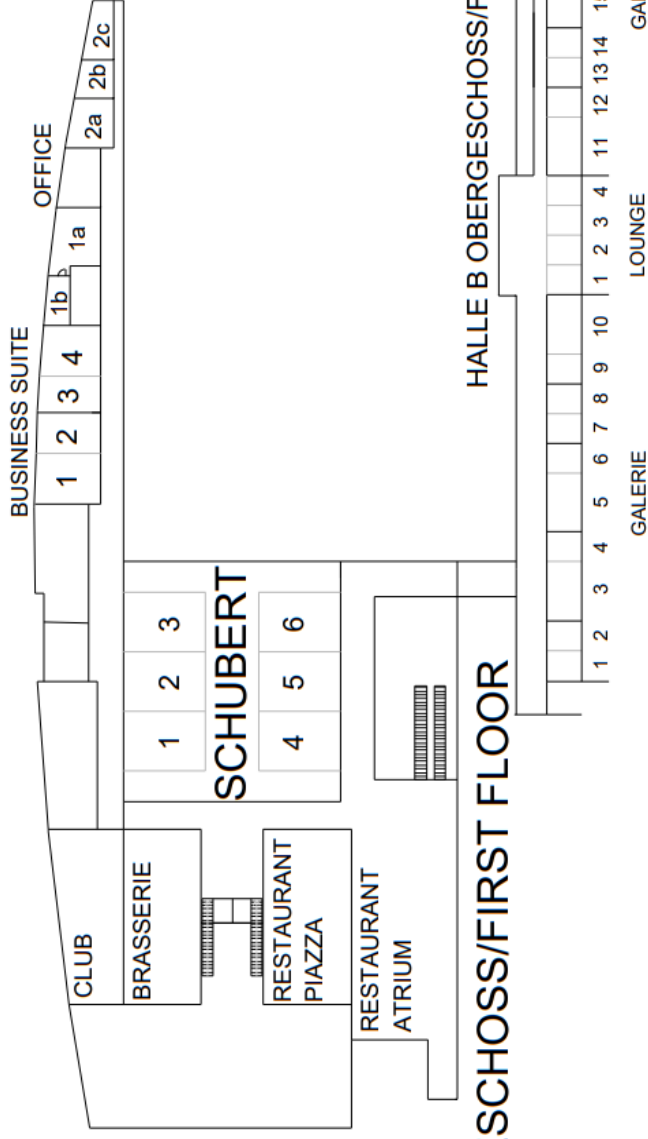

**CODE: AG17a / AG19a**

Position	<b>totems outside Foyer MCC</b>		
Dimension (WxH)	2 179 mm	5 090 mm	
Visible Area (WxH)	925 mm	5 090 mm	
Sides	front/back = double sided		
Material	PVC		
Total pieces	2		

Unit Price 625,50 €

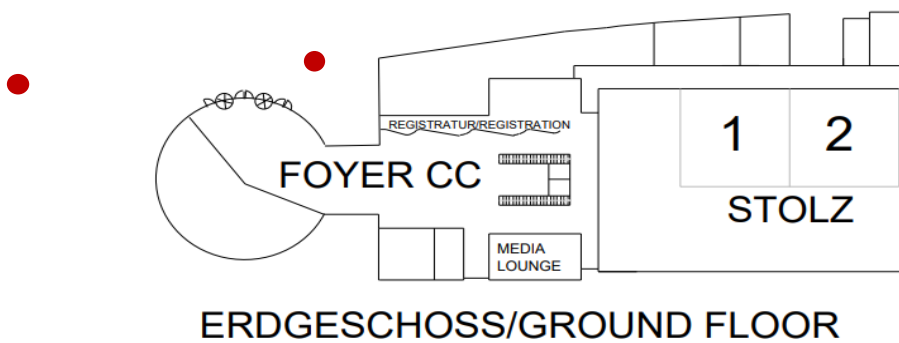
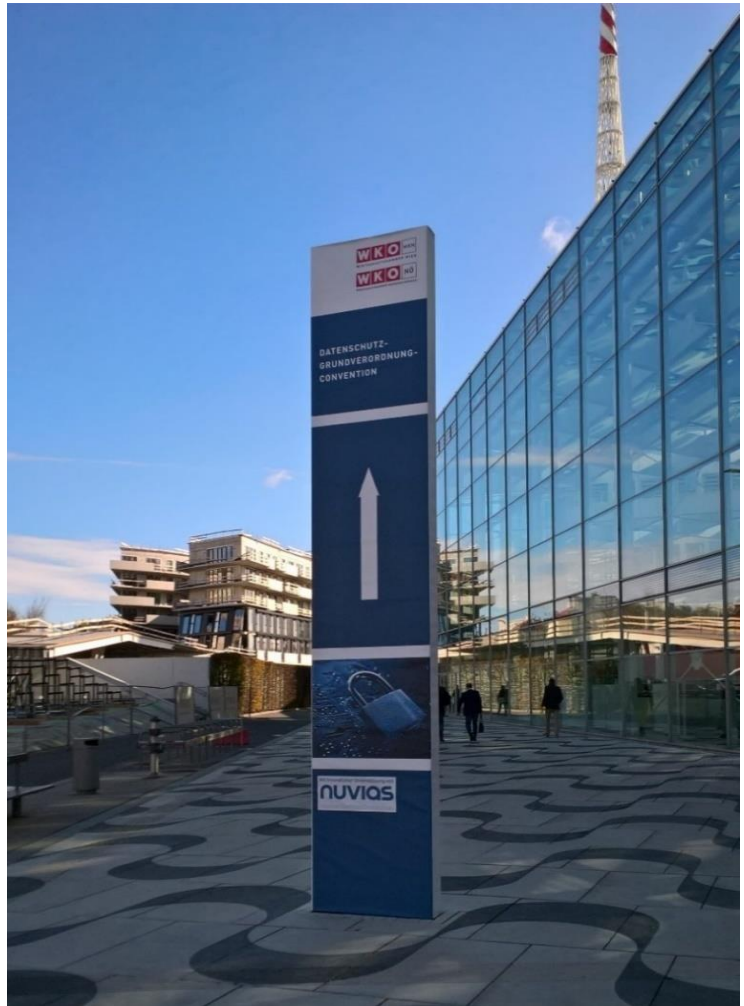
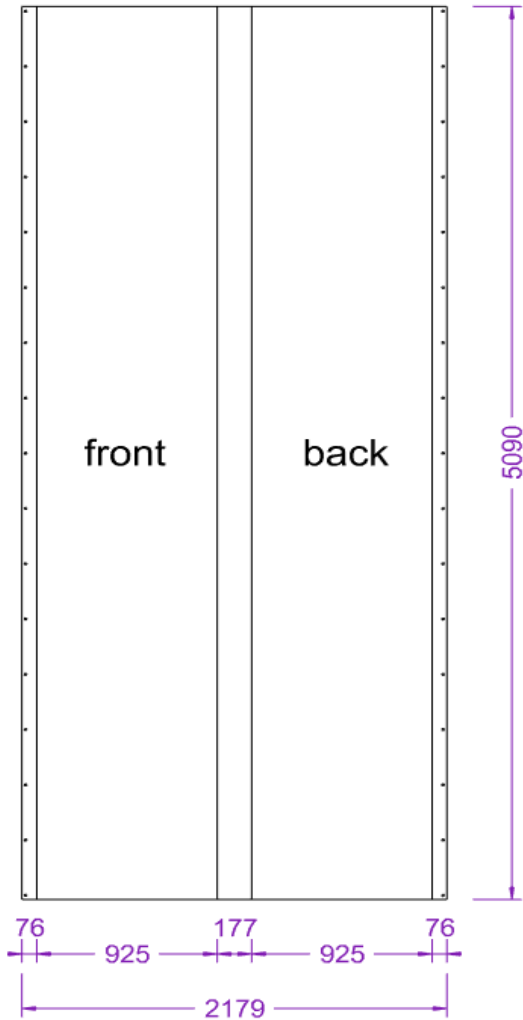

**CODE: AG17b / AG19b**

Position		totems outside Foyer MCC	
Dimension (WxH)		2 179 mm	2 300 mm
Visible Area (WxH)		925 mm	2 300 mm
Sides	front/back = double sided		
Material	PVC		
Total pieces	2		

Unit Price 316,00 €

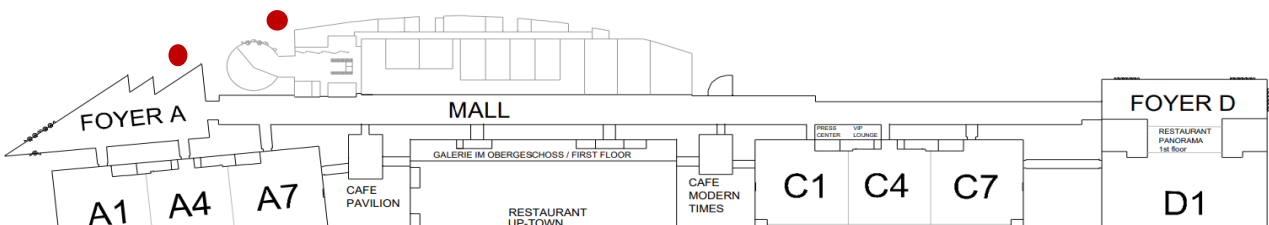
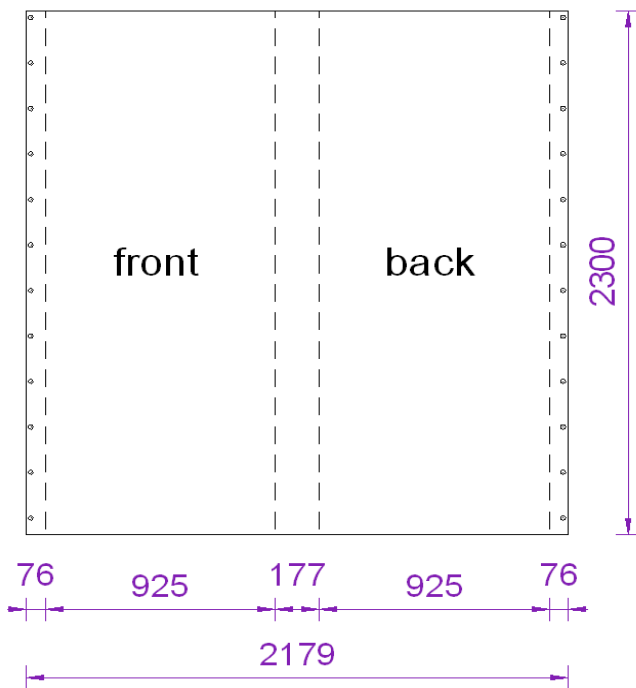

**CODE: REV5**

Position	<b>branding of outer windows of revolving doors Foyer MCC</b>		
Dimension (WxH)	1 090 mm	2 220 mm	
Visible Area (WxH)	1 090 mm	2 220 mm	
Sides	single sided		
Material	self adhesive foil		
Total pieces	8		

Unit Price 237,20 €

Price Total 1 897,60 €

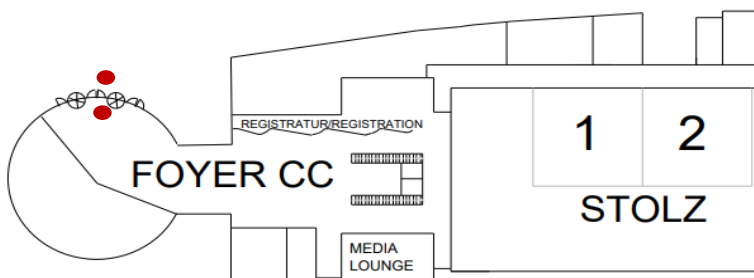
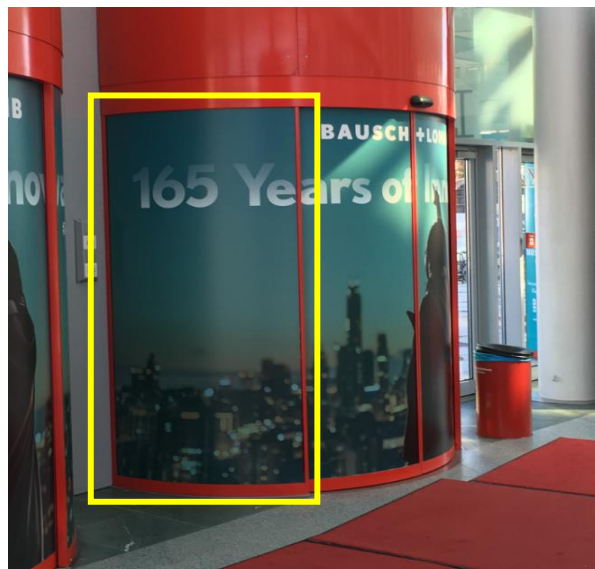
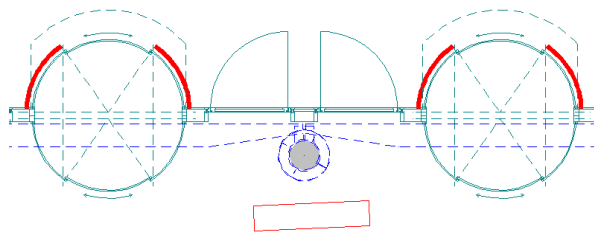

ERDGESCHOSS/GROUND FLOOR

**CODE: REV6**

Position	<b>branding of inner windows of revolving doors Foyer MCC</b>		
Dimension (WxH)	750 mm	2 225 mm	
Visible Area (WxH)	750 mm	2 225 mm	
Sides	single sided		
Material	self adhesive foil		
Total pieces	8		

Unit Price 230,60 €

Price Total 1 844,80 €

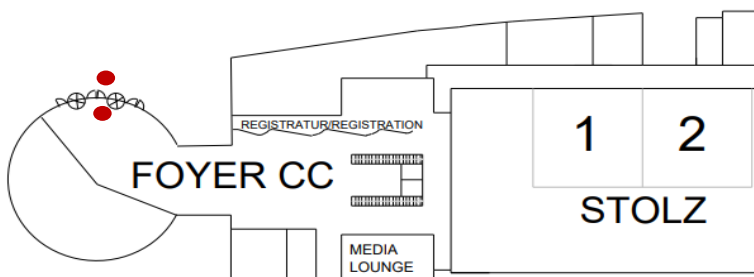
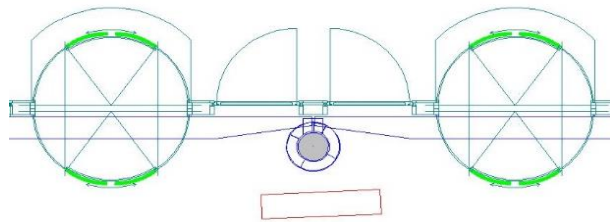

**ERDGESCHOSS/GROUND FLOOR**

**CODE: REV7**

Position	<b>branding above revolving doors (exterior / interior) Foyer MCC</b>		
Dimension (WxH)	3 920 mm	1 770 mm	
Visible Area (WxH)	3 920 mm	1 770 mm	
Sides	single sided		
Material	self adhesive foil		
Total pieces	4		

Unit Price (per side) 773,90 €

Price Total 3 095,60 €

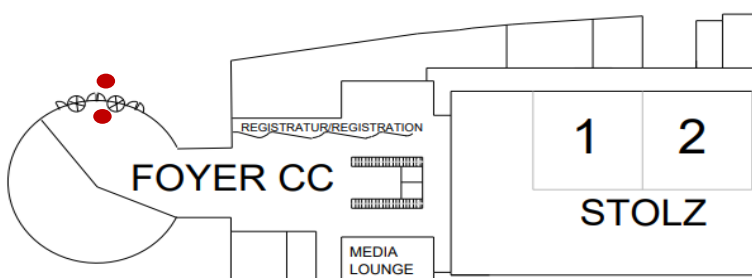
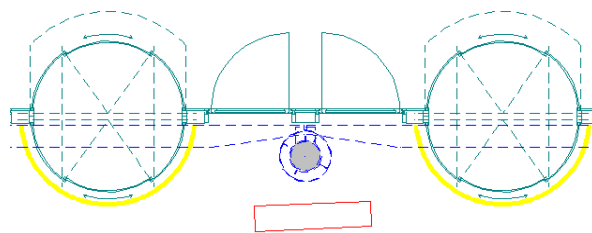

**ERDGESCHOSS/GROUND FLOOR**

**CODE: MCC1-MCC3**

Position		totem at Foyer MCC	
Dimension (WxH)	465 mm	2 600 mm	
Visible Area (WxH)	465 mm	2 600 mm	
Sides	single sided		
Material	forex, 3mm		
Total pieces	3		

Unit Price 133,40 €

Price Total 400,20 €

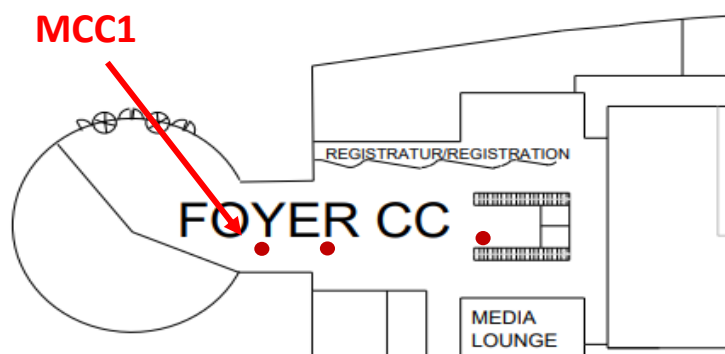

**CODE: WC1**

Position	<b>cladding of column Foyer MCC</b>		
Dimension (WxH)	535 mm	3 000 mm	
Visible Area (WxH)	535 mm	2 960 mm	
Sides	single side		
Material	frame with fabric covering on 4 sides		
Total pieces	8		

Unit Price 712,00 €

Price Total 5 696,00 €

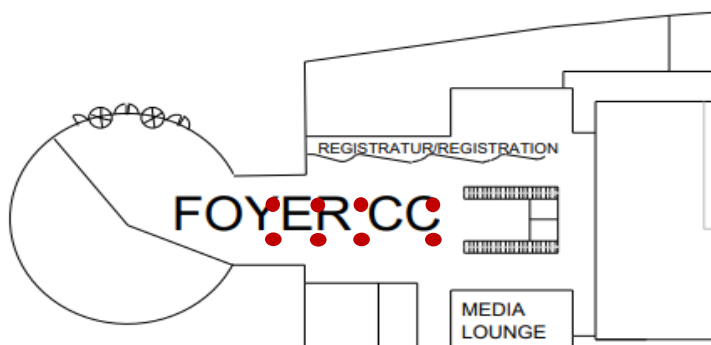

**CODE: REG1**

Position	<b>signage for registration Foyer MCC</b>		
Dimension (WxH)	-	-	-
Visible Area (WxH)	-	-	-
Sides	single side		
Material	frame with fabric covering		
Total pieces	1		

Unit Price 5 068,80 €

Price Total 5 068,80 €

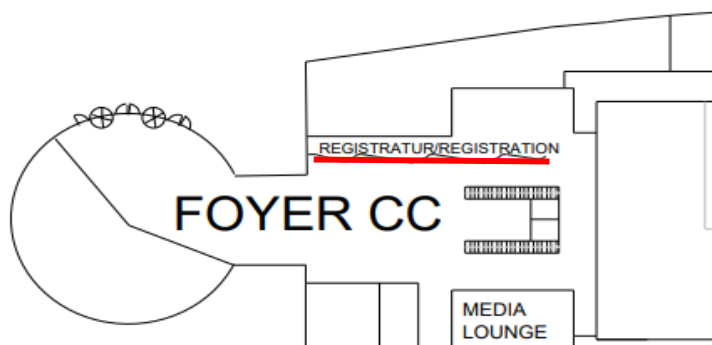
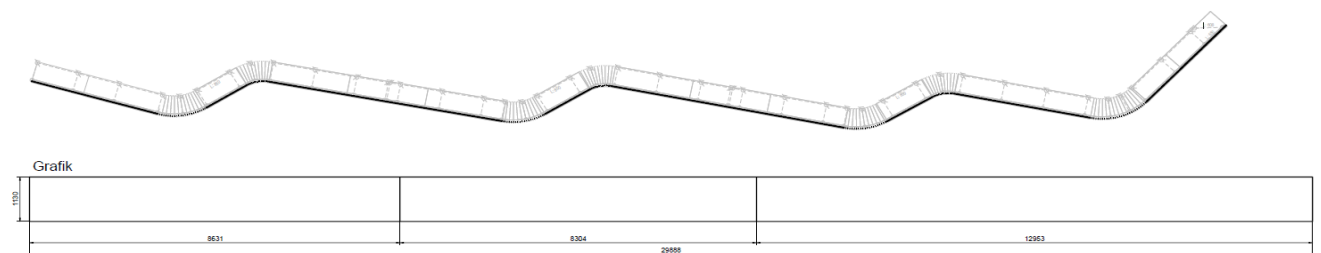

**CODE: MCC8**

Position	<b>glass banner, Foyer MCC</b>		
Dimension (WxH)	9 380 mm	1 400 mm	
Visible Area (WxH)	9 380 mm	1 400 mm	
Sides	single sided (backside covered white)		
Material	foam board, 5mm		
Total pieces	1		

Unit Price 1 453,30 €

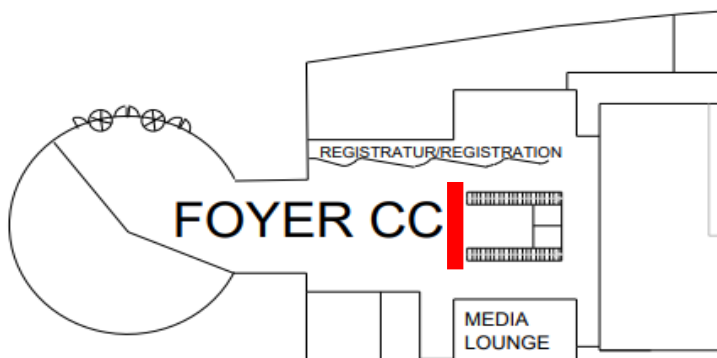

**CODE: SC4**

Position	<b>staircase branding Foyer MCC - riser</b>		
Dimension (WxH)	1 500 mm	125 mm	
Visible Area (WxH)	1 500 mm	125 mm	
Sides	single		
Material	self adhesive foil		
Total pieces	62 (31 left, 31 right)		

Unit Price 37,30 €

Price Total 2 312,60 €

foil on vertical part of the steps

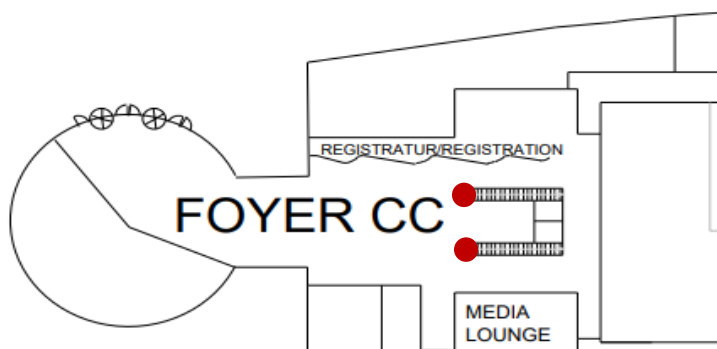
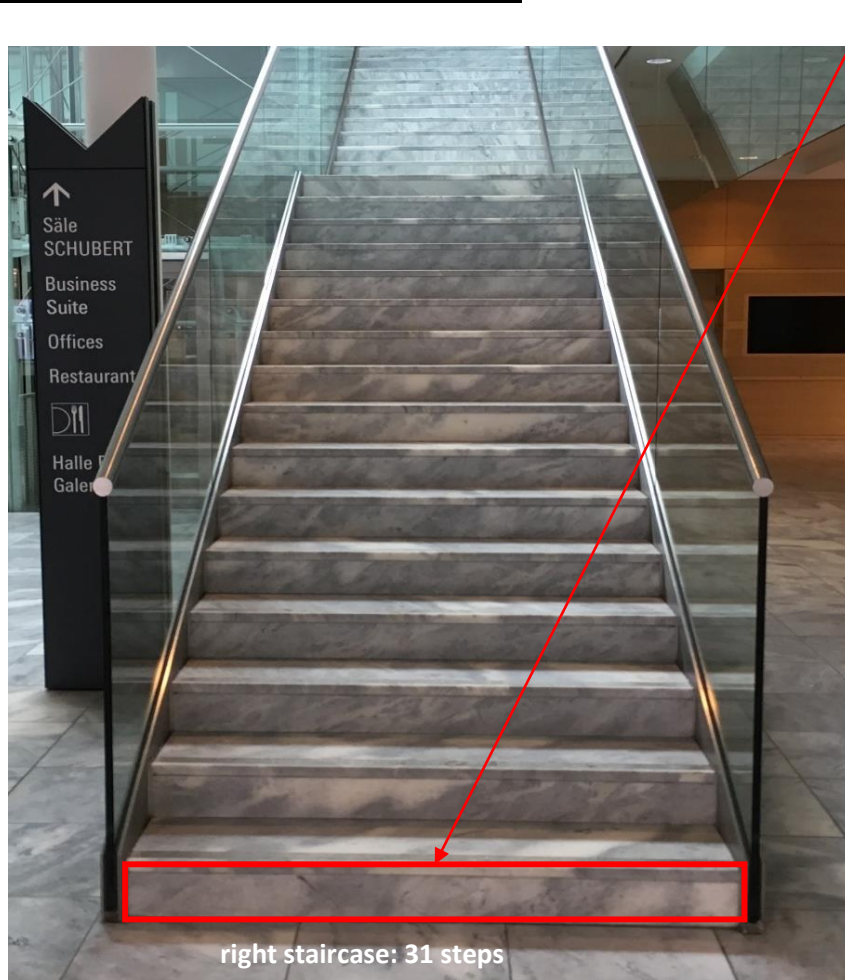

**CODE: SC5**

Position	<b>staircase branding Foyer MCC - tread</b>		
Dimension (WxH)	1 490 mm	1 490 mm	
Visible Area (WxH)	1 490 mm	1 490 mm	
Sides	single		
Material	self adhesive foil		
Total pieces	2 (1 left, 1 right)		

Unit Price 232,20 €

Price Total 464,40 €

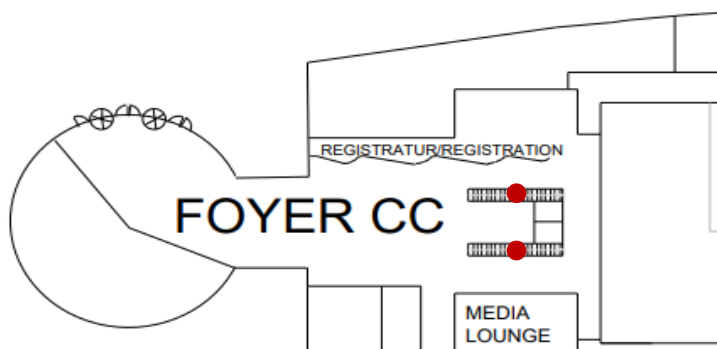

**CODE: MCCA**

Position		signage on totem	
Dimension	(WxH)	450 mm	2 190 mm
Visible Area	(WxH)	450 mm	2 190 mm
Sides		single side	
Material		forex, 3mm	
Total pieces		1	

Unit Price 115,90 €

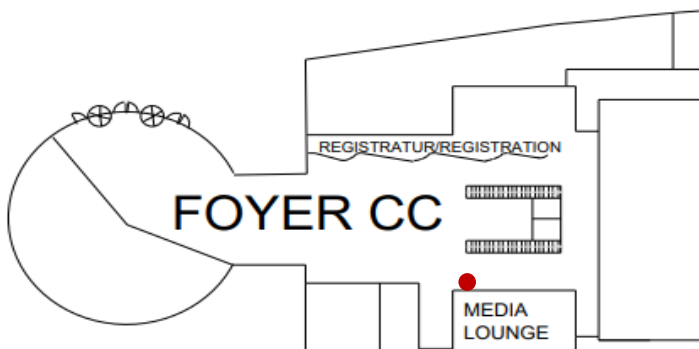

**CODE: MCC5**

Position		signage on totem (in front of Stolz rooms)	
Dimension	(WxH)	450 mm	2 400 mm
Visible Area	(WxH)	450 mm	2 400 mm
Sides		single side	
Material		forex, 3mm	
Total pieces		1	

Unit Price 119,80 €

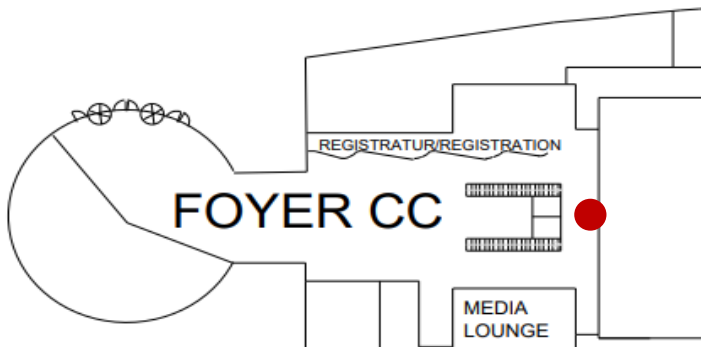

**CODE: MCC6 / MCC7**

Position	<b>signage on totem (front of Schubert rooms)</b>		
Dimension (WxH)	480 mm	2 400 mm	
Visible Area (WxH)	480 mm	2 400 mm	
Sides	single side		
Material	forex, 3mm		
Total pieces	2		

Unit Price 123,30 €

Price Total 246,60 €

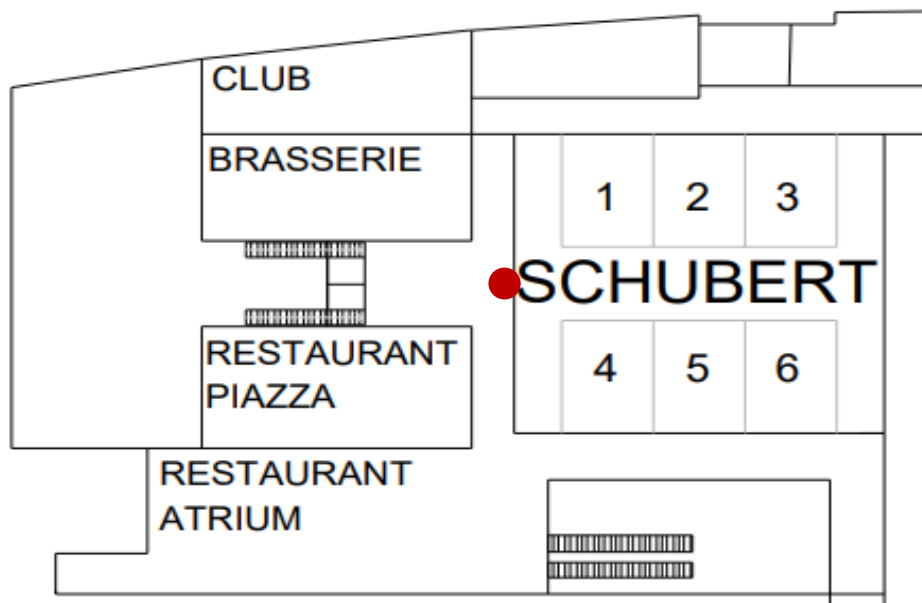

**CODE: MCC rooms**

Position		Sign above MCC Rooms	
Dimension	(WxH)	2 065 mm	500 mm
Visible Area	(WxH)	2 065 mm	500 mm
Sides		single sided	
Material		foam board, 5mm	
Total pieces		29	

Unit Price 108,90 €

other dimensions are possible



# STAND<sup>OUT</sup>

be visible

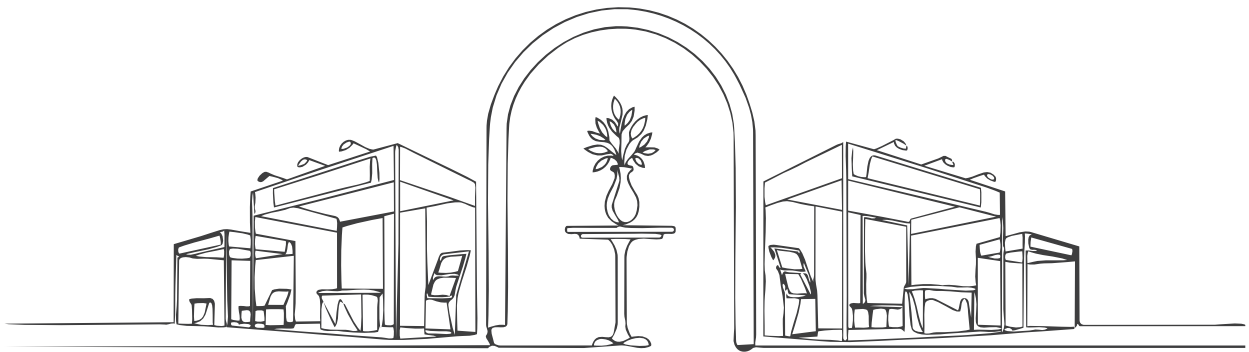

## **SIGNAGE „FOYER D“**

---

AND SURROUNDING

2026



# EXHIBITION CENTER

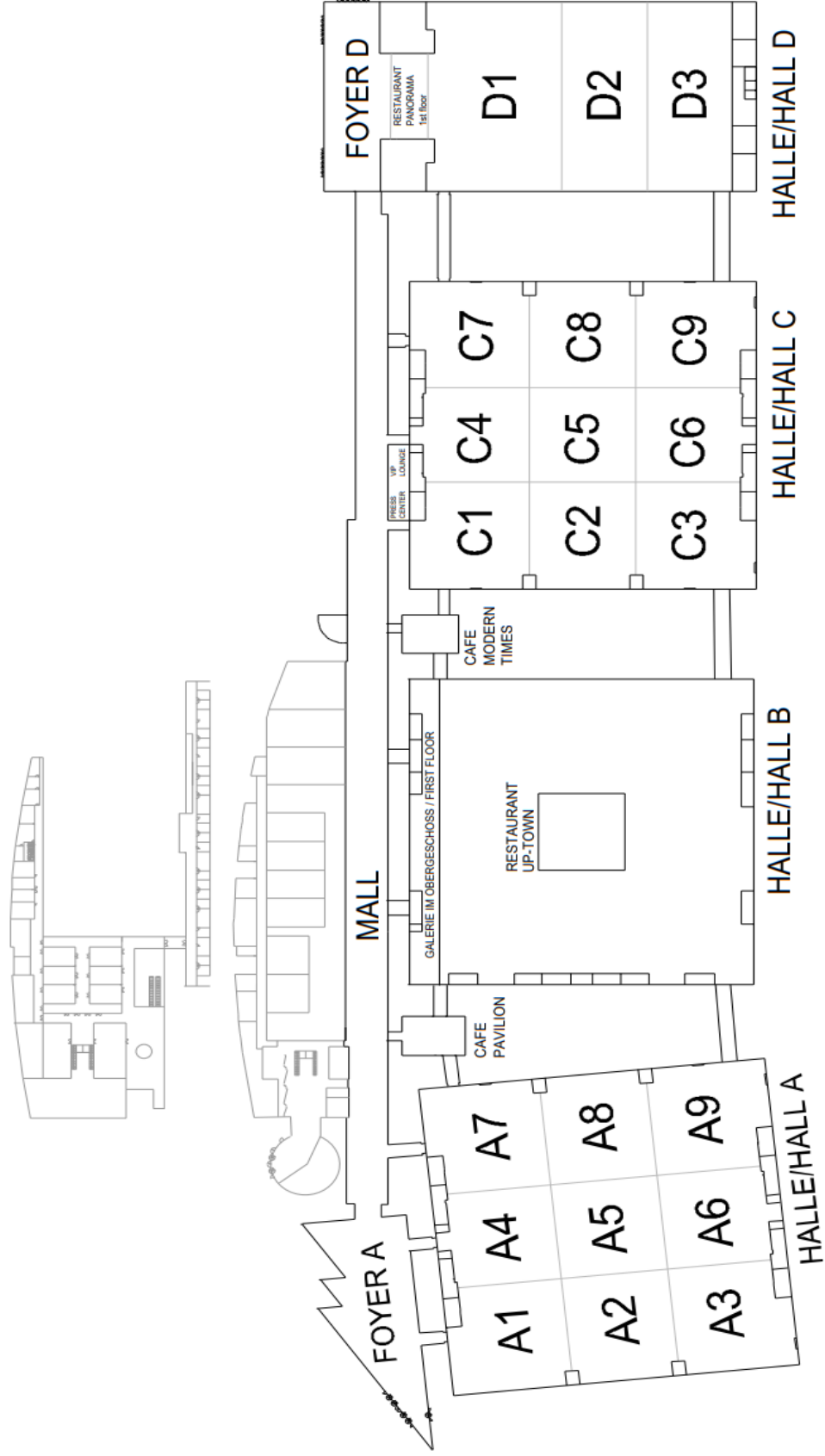

**CODE: AG23a-AG26a**

Position	<b>signage on totem (outside Foyer D)</b>		
Dimension (WxH)	2 179 mm	5 090 mm	
Visible Area (WxH)	925 mm	5 090 mm	
Sides	front/back = double sided		
Material	PVC		
Total pieces	4		

Unit Price 625,50 €

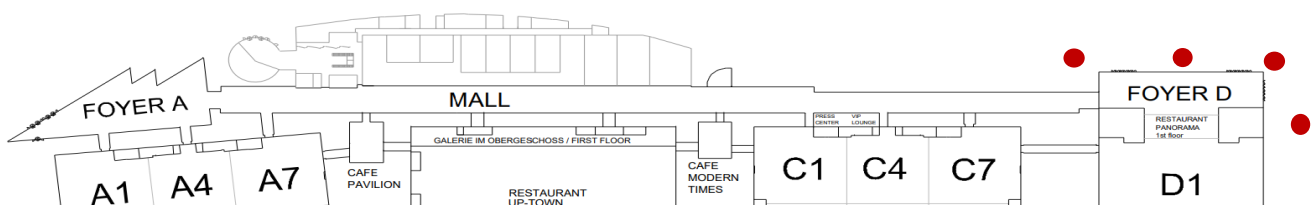
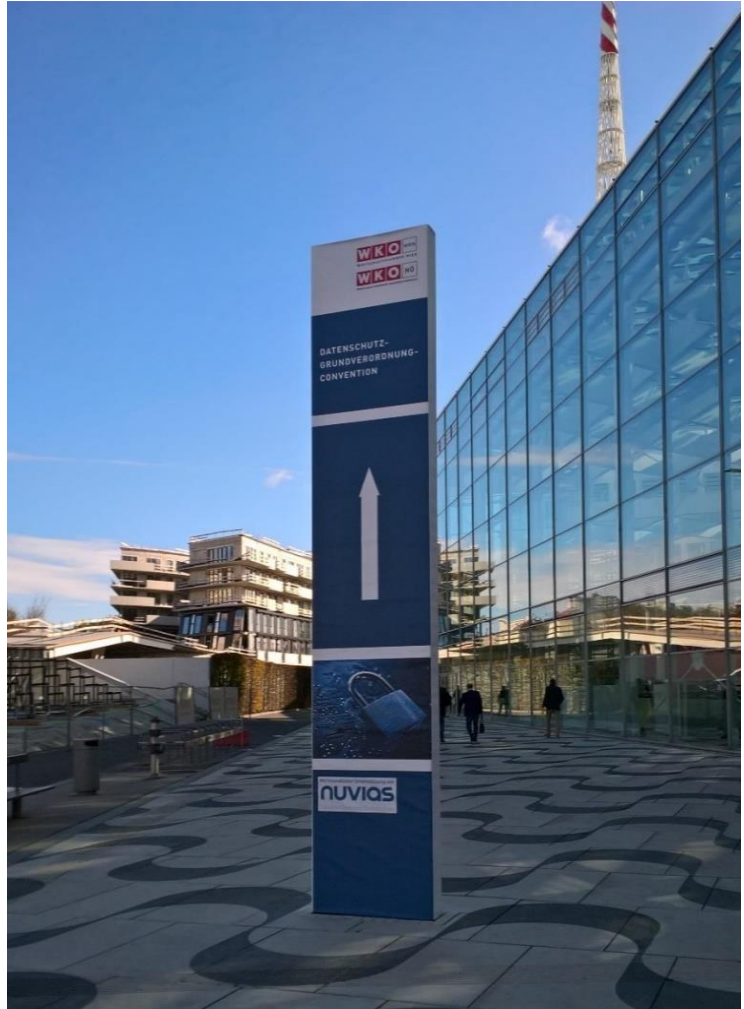
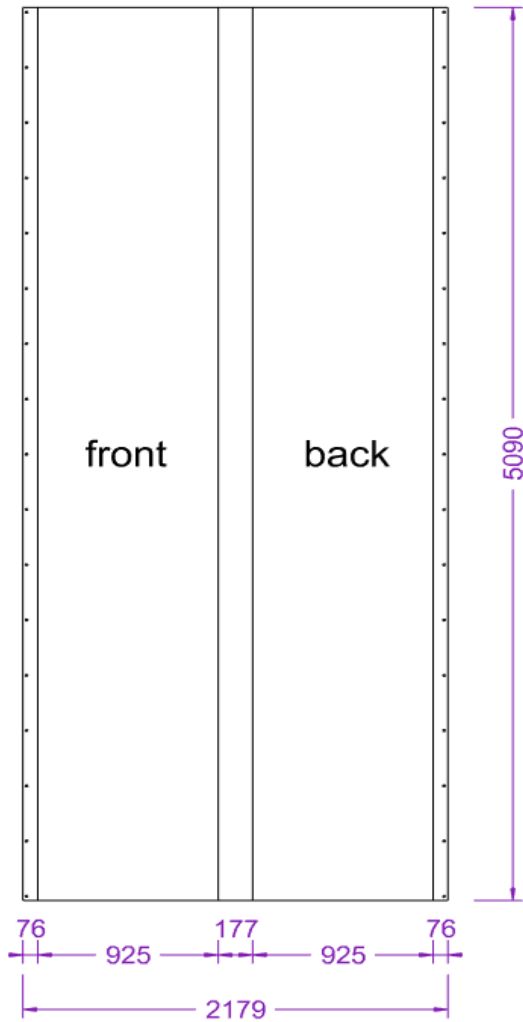

**CODE: AG23b-AG26b**

Position	<b>signage on totem (outside Foyer D)</b>	
Dimension (WxH)	2 179 mm	2 300 mm
Visible Area (WxH)	925 mm	2 300 mm
Sides	front/back = double sided	
Material	PVC	
Total pieces	4	

Unit Price 316,00 €

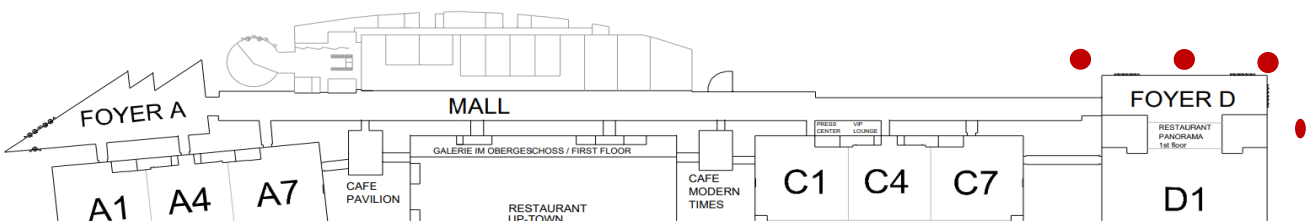
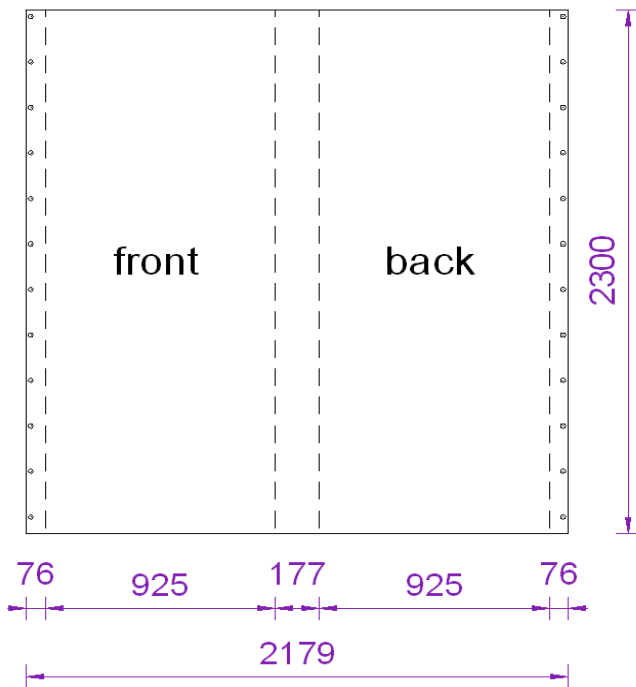

**CODE: AG7-AG12**

Position		flag poles outside Foyer D	
Dimension (WxH)		1 200 mm	8 000 mm
Visible Area (WXH)		1 200 mm	8 000 mm
Sides		single sided	
Material		flag fabric, rattling flag	
Total pieces		6	

Unit Price 297,30 €

Price Total 1 783,80 €



mounting of flags will be done and charged by Reed Messe

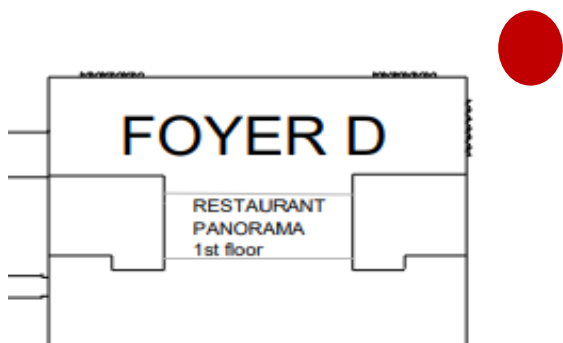

**CODE: FD13**

Position		branding of glass panels Foyer D outside	
Dimension (WxH)		11 945 mm	4 484 mm
Visible Area (WxH)		3 975 mm	2 234 mm
Sides		single sided	
		self adhesive foil	
Total pieces		6	

Unit Price 818,90 €

Price Total 4 913,40 €

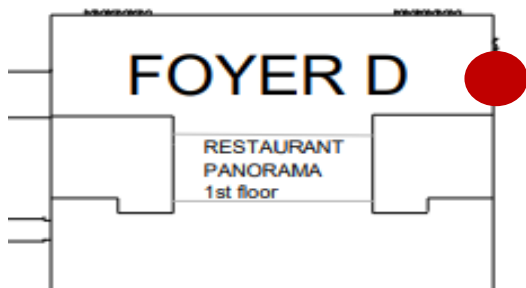
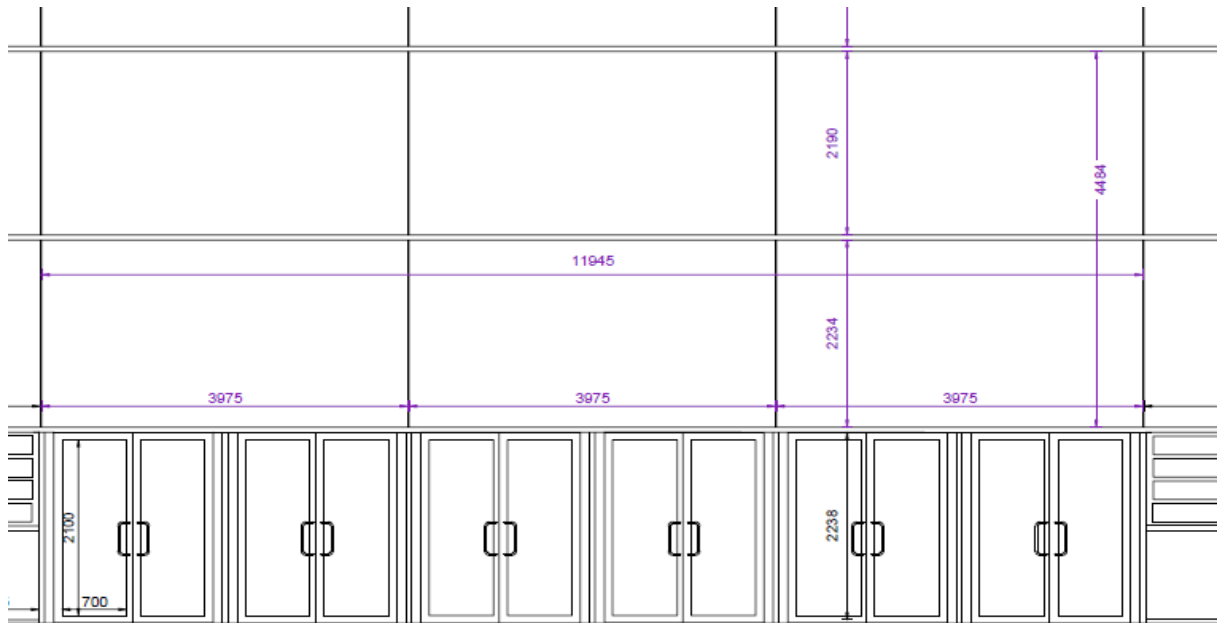

**CODE: FD14**

Position		branding of glass panels Foyer D outside	
Dimension (WxH)		11 945 mm	4 484 mm
Visible Area (WxH)		3 975 mm	2 234 mm
Sides		single sided	
Material		self adhesive foil	
Total pieces		12 (6 left, 6 right)	

Unit Price 818,90 €

Price Total 9 826,80 €

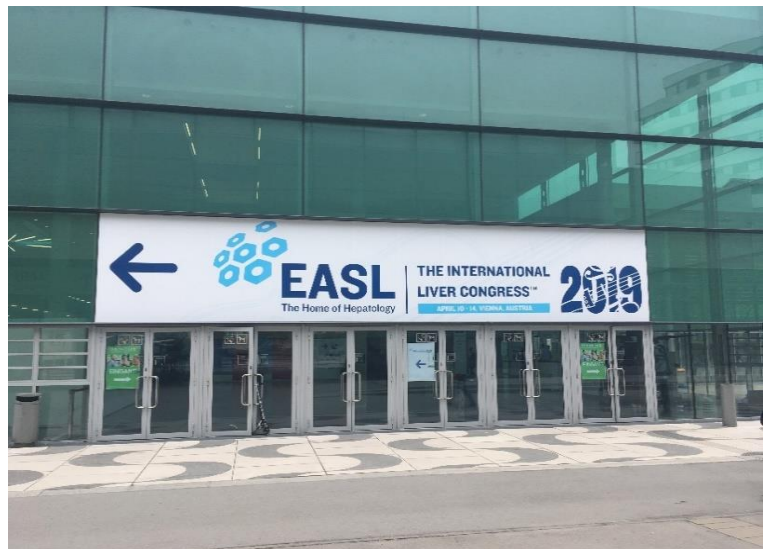
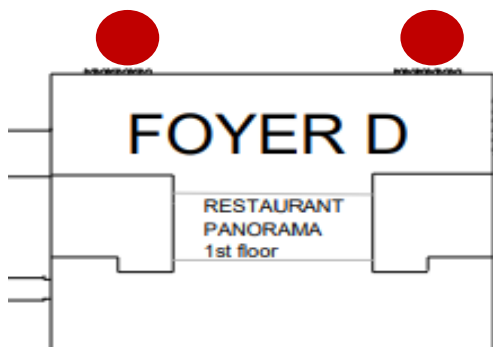
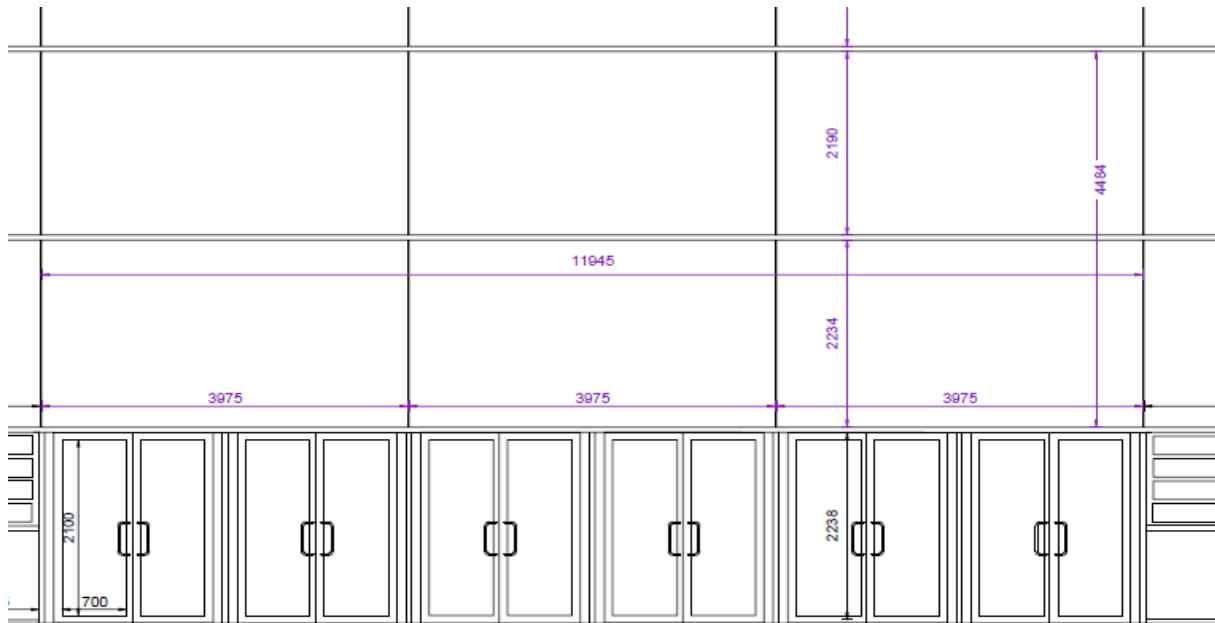

**CODE: FD2, FD3, FD4**

Position		signage on totem in Foyer D	
Dimension (WxH)	915 mm	5 130 mm	
Visible Area (WxH)	915 mm	5 130 mm	
Sides	single sided		
Material	forex, 3mm		
Total pieces	3		

Unit Price 382,40 €

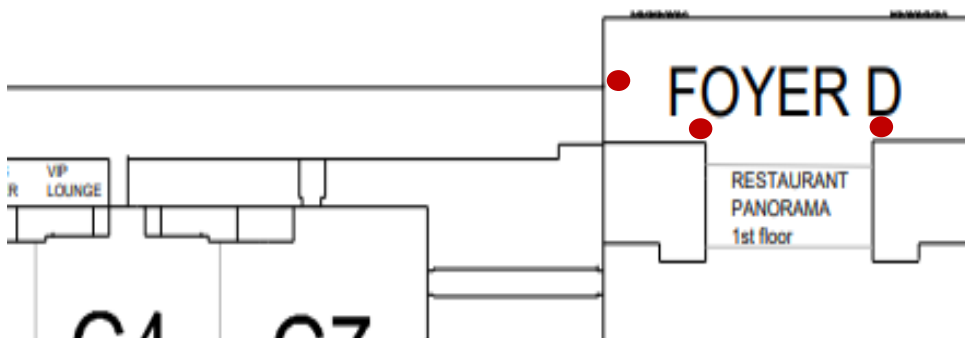
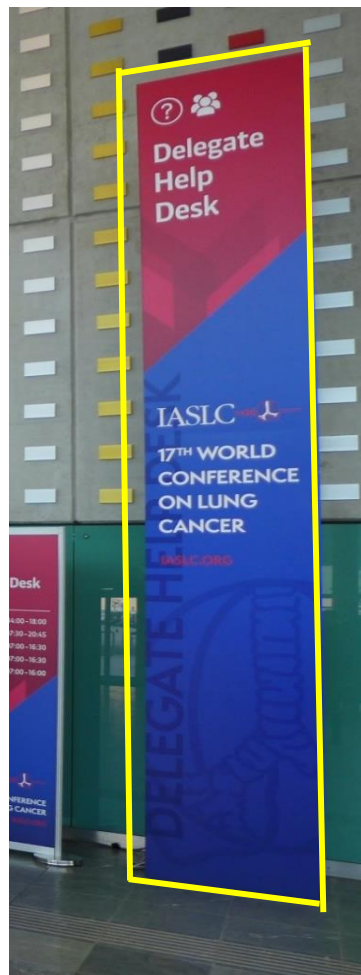

**CODE: FD5, FD6**

Position		signage on totem in Foyer D	
Dimension (WxH)	695 mm	3 860 mm	
Visible Area (WxH)	695 mm	3 860 mm	
Sides	single sided		
Material	forex, 3mm		
Total pieces	2		

Unit Price 220,20 €

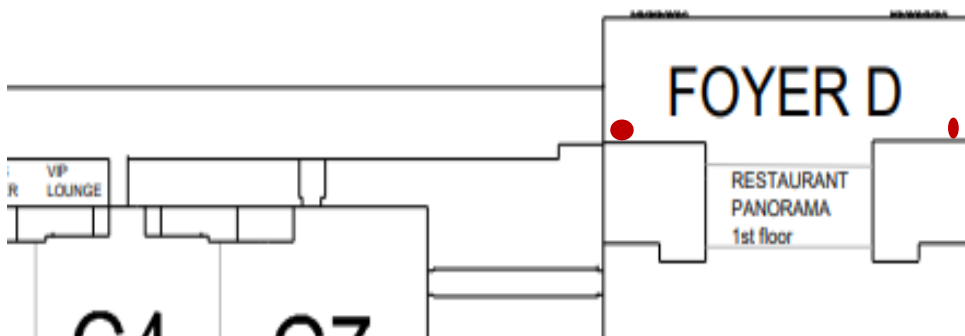
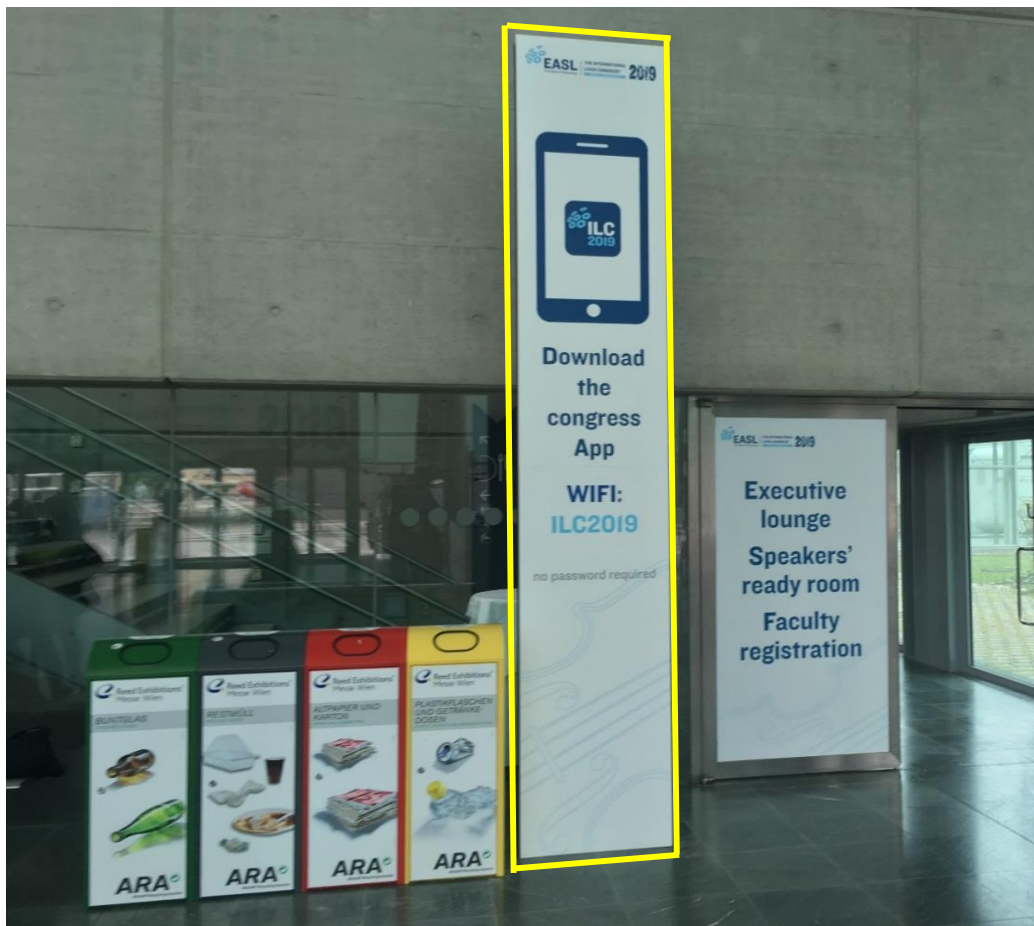

**CODE: FD1**

Position	<b>signage on overhead signpost above entrance to Mall</b>		
Dimension (WxH)	4 500 mm	2 550 mm	(max H=4300mm)
Visible Area (WxH)	4 500 mm	2 550 mm	(max H=4300mm)
Sides	single sided		
Material	graphic fabric		
Total pieces	1		

Unit Price 863,20 €

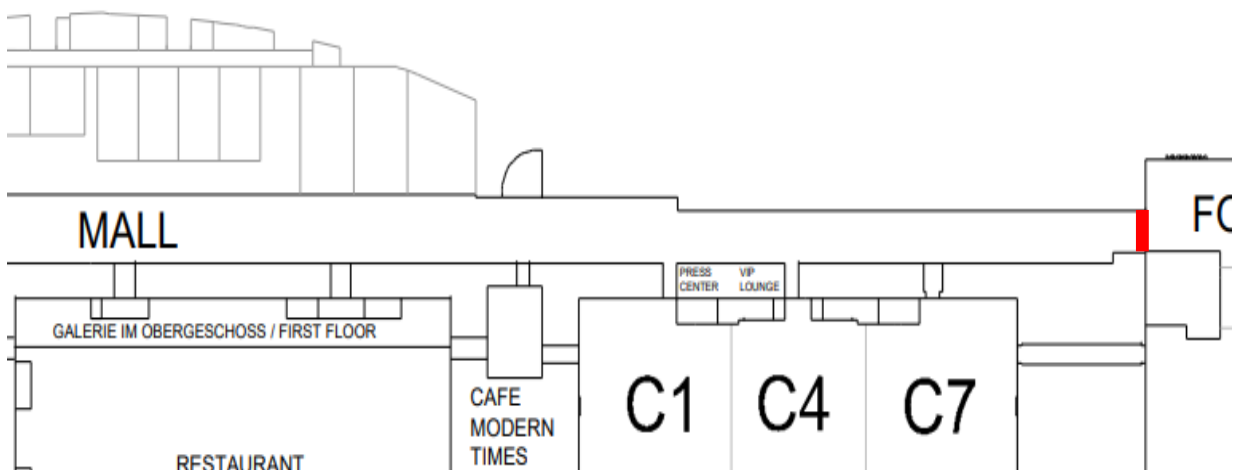

**CODE: FDB1**

Position	<b>banner between totems Foyer D</b>		
Dimension (WxH)	7 500 mm	1 500 mm	
Visible Area (WxH)	7 500 mm	1 500 mm	
Sides	double sided		
Material	PVC		
Total pieces	1		

Unit Price 1 124,00 €

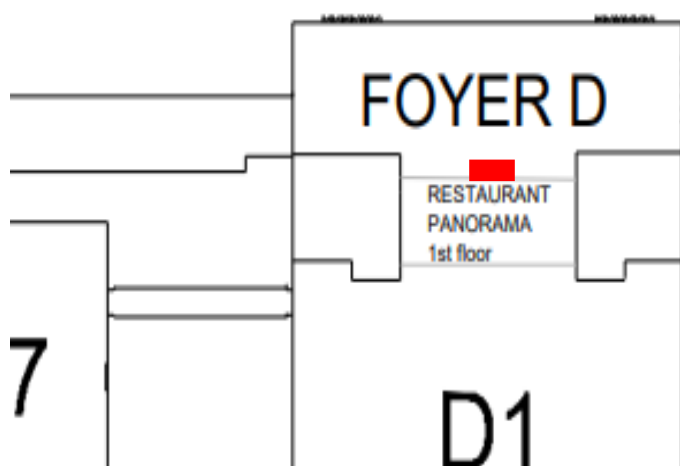
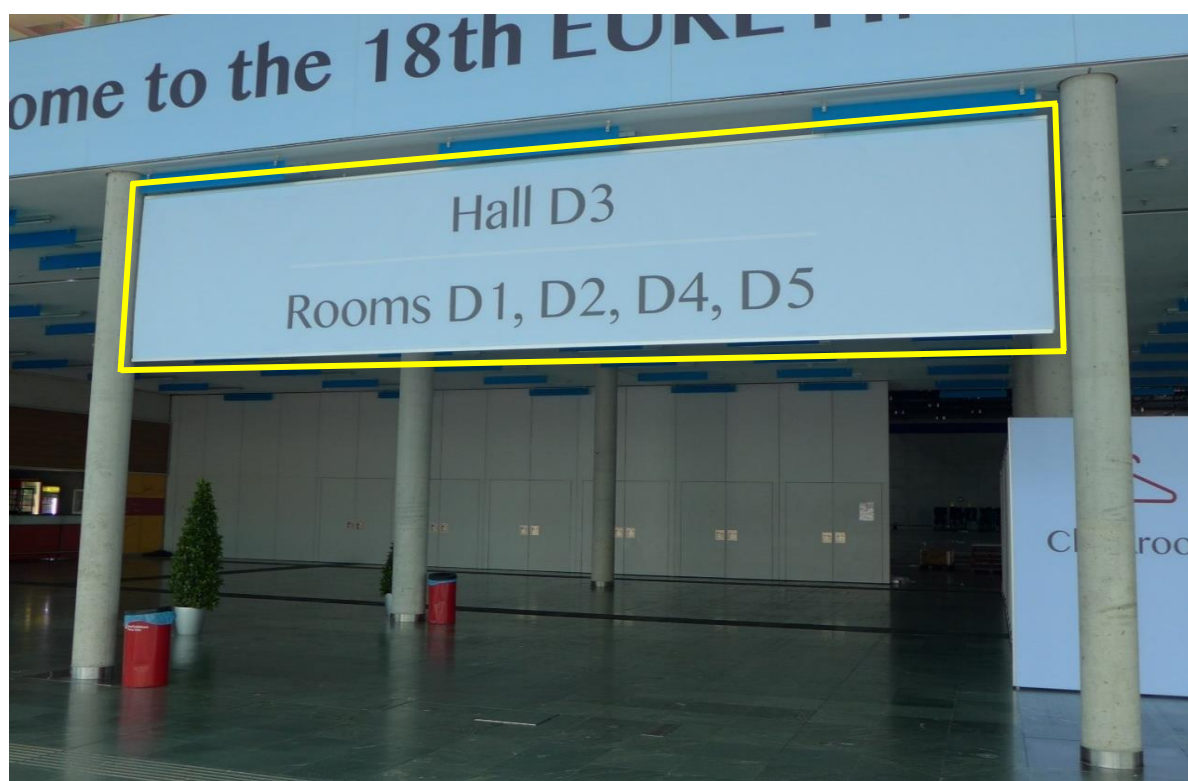

**CODE: FDB2**

Position	<b>banner between totems Foyer D</b>		
Dimension (WxH)	7 500 mm	3 000 mm	
Visible Area (WxH)	7 500 mm	3 000 mm	
Sides	single sided		
Material	graphic fabric		
Total pieces	3		

Unit Price 1 393,60 €

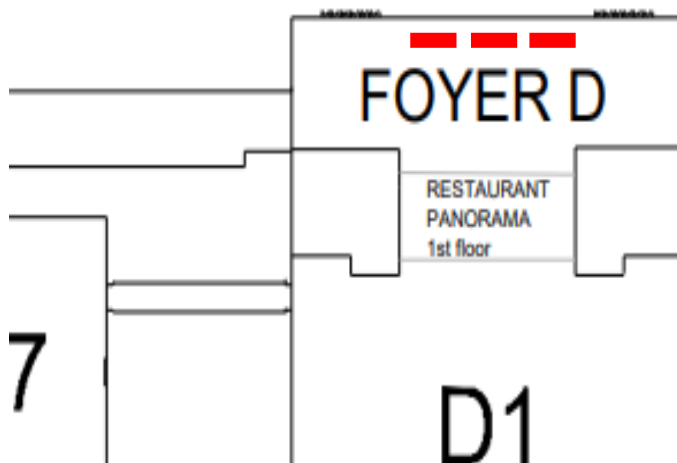

**CODE: FD15**

Position	<b>signage on glass front - restaurant Foyer D</b>		
Dimension (WxH)	36 000 mm	1 370 mm	
Visible Area (WxH)	36 000 mm	1 370 mm	
Sides	single sided		
Material	foam board, 5mm		
Total pieces	1		

Unit Price 4 961,80 €

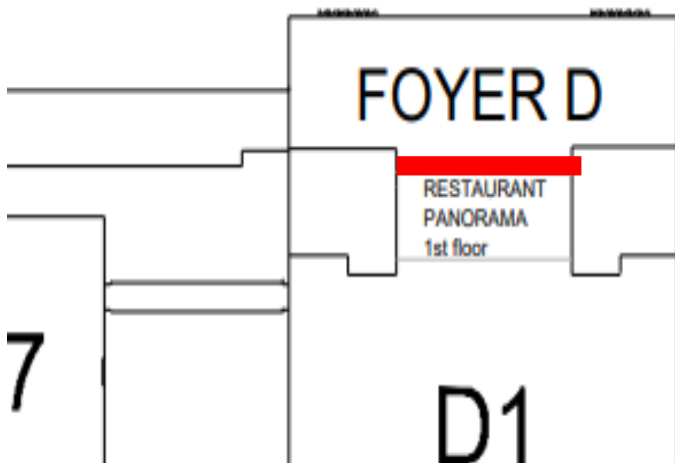

**CODE: FD16**

Position	<b>signage on glass front - restaurant Foyer D</b>		
Dimension (WxH)	36 000 mm	1 000 mm	
Visible Area (WxH)	36 000 mm	1 000 mm	
Sides	single sided		
Material	self adhesive foil		
Total pieces	1		

Unit Price 4 414,90 €

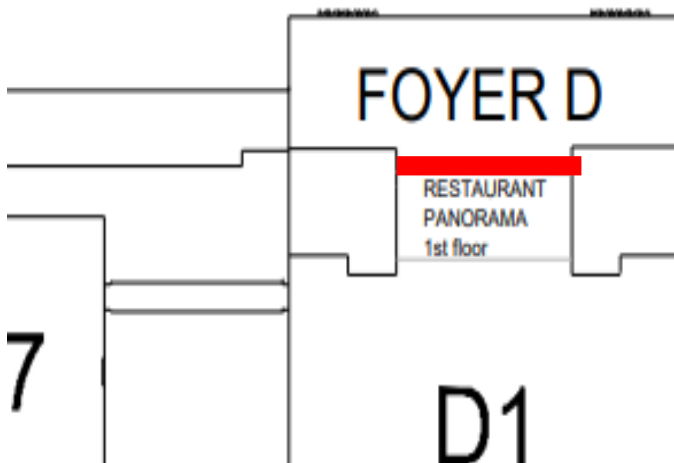

**CODE: FD17**

Position	<b>signage on ground floor glass panels Foyer D</b>		
Dimension (WxH)	990 mm	2 170 mm	
Visible Area (WxH)	990 mm	2 170 mm	
Sides	single sided		
Material	self adhesive foil		
Total pieces	16 (8 left, 8 right)		

Unit Price 203,20 €

Price Total (all 8 pcs) 3 251,20 €

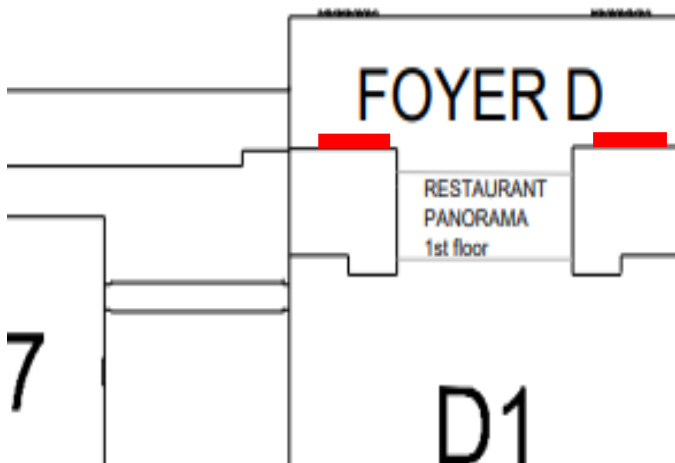

**CODE: FD18**

Position		signage on door panels Foyer D	
Dimension (WxH)		1 060 mm	2 030 mm
Visible Area (WxH)		1 060 mm	2 030 mm
Sides		single sided	
Material		self adhesive foil	
Total pieces		4 (1 double door left, 1 double door right)	

Unit Price 205,20 €

Price Total (all 4 pcs) 820,80 €

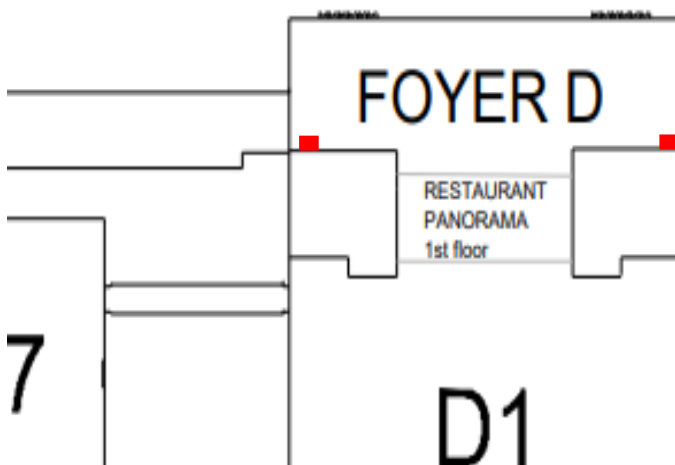
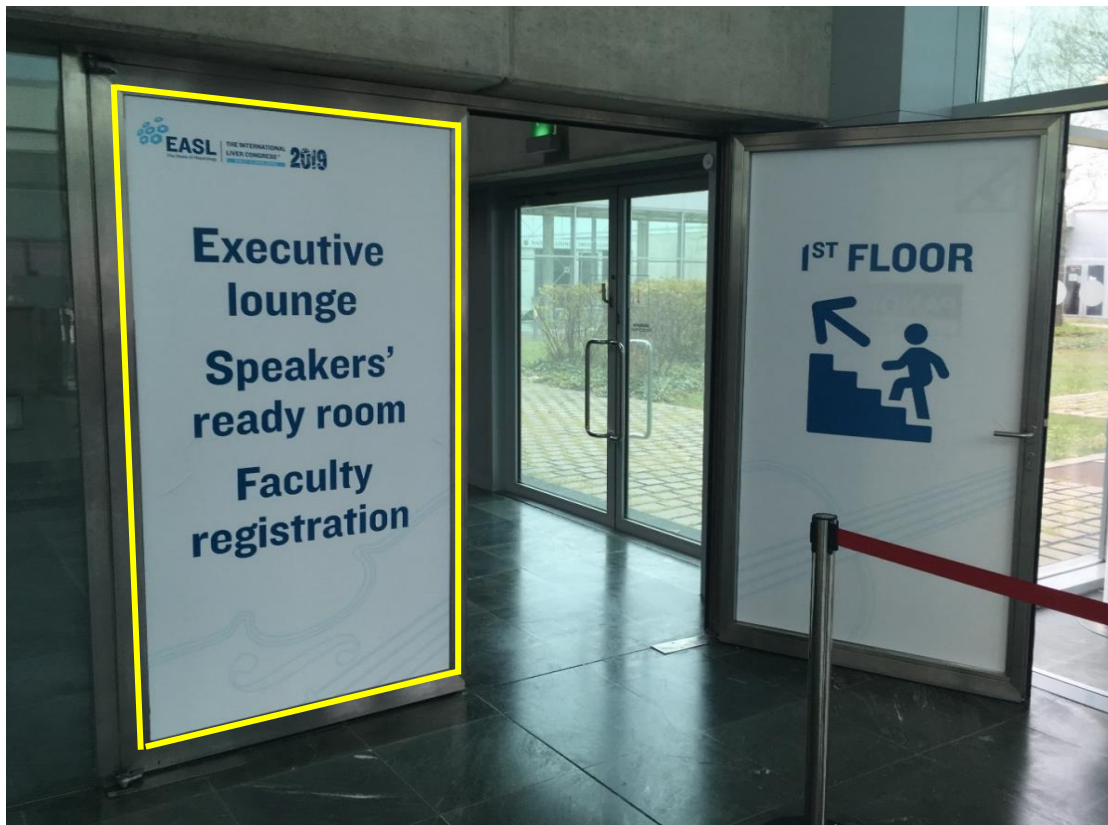

**CODE: SC6**

Position	<b>branding of staircase to restaurant - riser Foyer D</b>		
Dimension (WxH)	2 480 mm	160 mm	
Visible Area (WxH)	2 480 mm	160 mm	
Sides	single		
Material	self adhesive foil		
Total pieces	36 (18 lower part, 18 upper part)		

Unit Price 66,20 €

Price Total 2 383,20 €

foil on vertical part of the steps

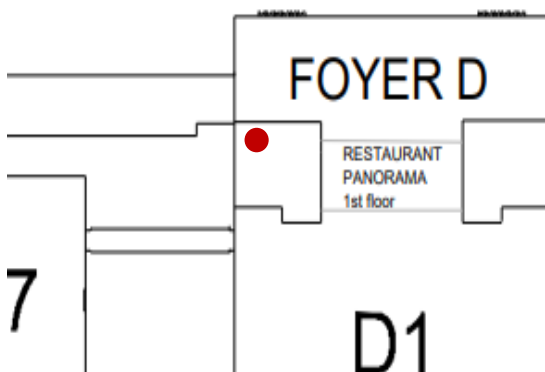
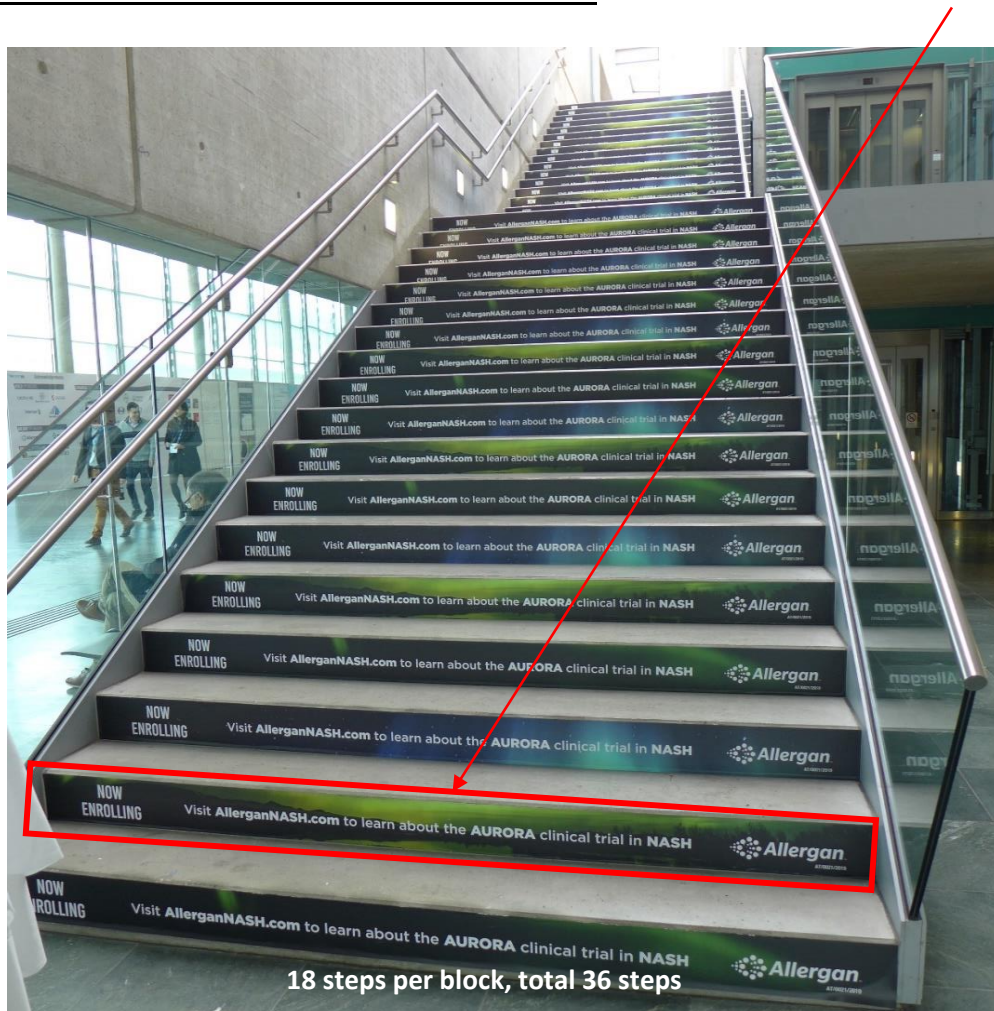

# STAND<sup>OUT</sup>

be visible



## SIGNAGE GENERAL

---

2026



**CODE: FS1**

Position		floor stickers	
Dimension	(WxH)	1 000 mm	1 000 mm
Visible Area	(WxH)	1 000 mm	1 000 mm
Sides		single	
Material		self adhesive foil	
Total pieces		several	

Unit Price 192,90 €



**CODE: LEC1**

Position		front panel for lectern	
Dimension	(WxH)	600 mm	1 180 mm
Visible Area	(WxH)	600 mm	1 180 mm
Sides		single sided	
Material		forex, 3mm	
Total pieces		-	

Unit Price

---



**The lectern is not included!**

**CODE: PT1**

Position		front panel for podium tables	
Dimension	(WxH)	3 100 mm	800 mm (Width of two tables)
Visible Area	(WxH)	3 100 mm	800 mm
Sides		single sided	
Material		forex, 3mm	
Total pieces		-	

Unit Price 170,80 €





**CODE: SS1-BS**

Position	<b>Self Standing Sign large (2x4m)</b>		
Dimension (WxH)	4 000 mm	2 000 mm	
Visible Area (WxH)	4 000 mm	2 000 mm	
Sides	double sided		
Material	frame with small base plates and fabric covering		
Total pieces	1		

Unit Price 1 193,40 €



**CODE: SS2-ES**

Position	<b>Self Standing Sign medium (2x2m)</b>		
Dimension (WxH)	2 000 mm	2 000 mm	
Visible Area (WxH)	2 000 mm	2 000 mm	
Sides	single sided		
Material	frame with small base plates and fabric covering		
Total pieces	1		

Unit Price 479,40 €



**CODE: SS2-BS**

Position	<b>Self Standing Sign medium (2x2m)</b>		
Dimension (WxH)	2 000 mm	2 000 mm	
Visible Area (WxH)	2 000 mm	2 000 mm	
Sides	double sided		
Material	frame with small base plates and fabric covering		
Total pieces	1		

Unit Price 610,60 €



**CODE: SS3-ES**

Position		Self Standing Sign small (2x1m)	
Dimension	(WxH)	1 000 mm	2 000 mm
Visible Area	(WxH)	1 000 mm	2 000 mm
Sides		single sided	
Material		frame with small base plates and fabric covering	
Total pieces		1	

Unit Price 327,90 €



**CODE: SS3-BS**

Position		Self Standing Sign small (2x1m)	
Dimension	(WxH)	1 000 mm	2 000 mm
Visible Area	(WxH)	1 000 mm	2 000 mm
Sides		double sided	
Material		frame with small base plates and fabric covering	
Total pieces		1	

Unit Price 393,50 €



**CODE: TO1**

Position		Self Standing Tower signage	
Dimension (WxH)		1 030 mm	2 500 mm / construction
Visible Area (WxH)		950 mm	2 380 mm / visible graphic dimension
Graphic dim. (WxH)		964 mm	2 400 mm / required graphic data
Sides		four sided	
Material		print on infill, 3mm	
Total pieces		1	

Unit Price 334,20 €

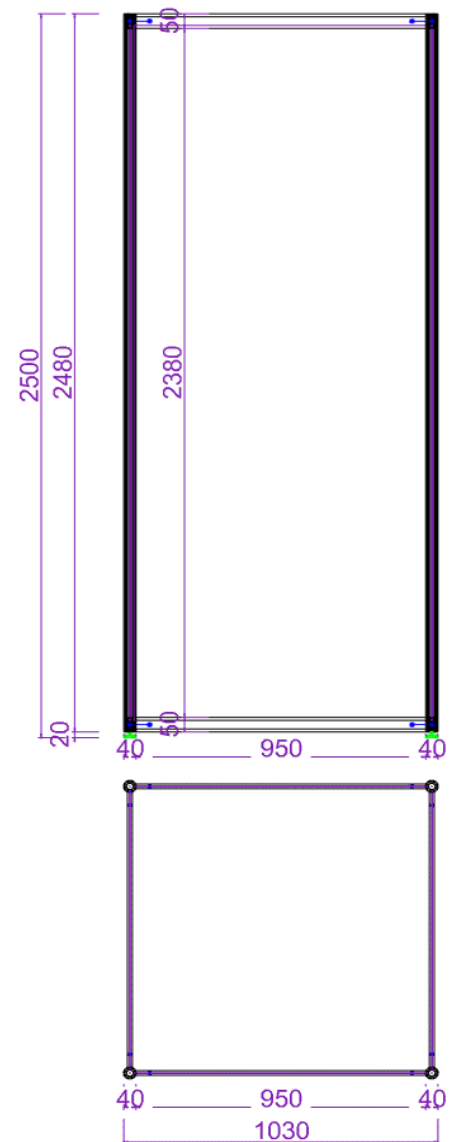
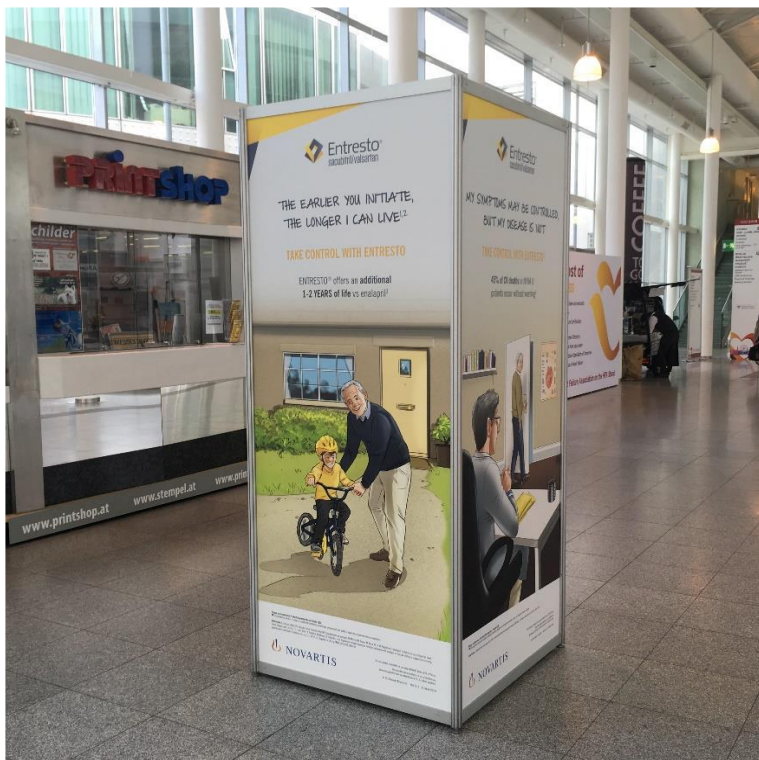

**CODE: LO1**

Position		Self Standing Sign "Lollipop"	
Dimension	(WxH)	594 mm	841 mm
Visible Area	(WxH)	594 mm	841 mm
Sides		single sided	
Material		foam board, 5mm	
Total pieces		1	

Unit Price 119,10 €



**CODE: LO2**

Position		Self Standing Sign "Lollipop"	
Dimension	(WxH)	594 mm	841 mm
Visible Area	(WxH)	594 mm	841 mm
Sides		double sided	
Material		foam board, 5mm	
Total pieces		1	

Unit Price 151,50 €



# STAND<sup>OUT</sup>

be visible

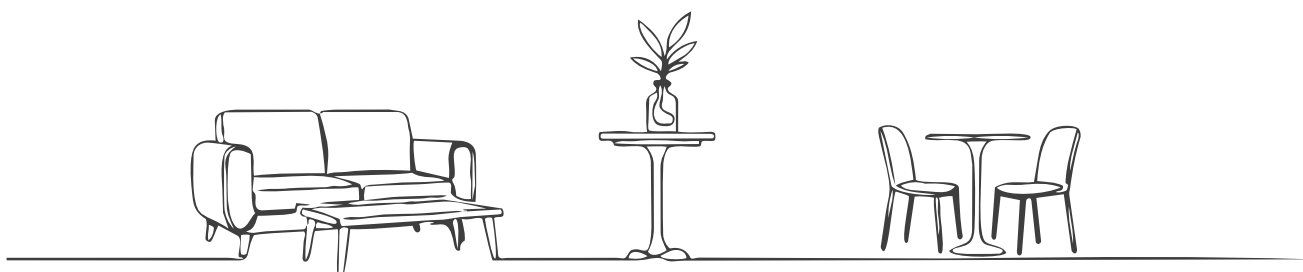

## VIECON BRANDABLE FURNITURE

---

2026

**VIE  
CON**

**CODE: LEC2**

Position		Panel for lectern, MCC	
Dimension (WxH)	570 mm	1 045 mm	
Visible Area (WxH)	570 mm	1 045 mm	
Sides	single		
Material	forex, 3mm		
Total pieces	-		

Unit Price 69,70 €

*Lectern provided by Messe  
(for MCC only!)*

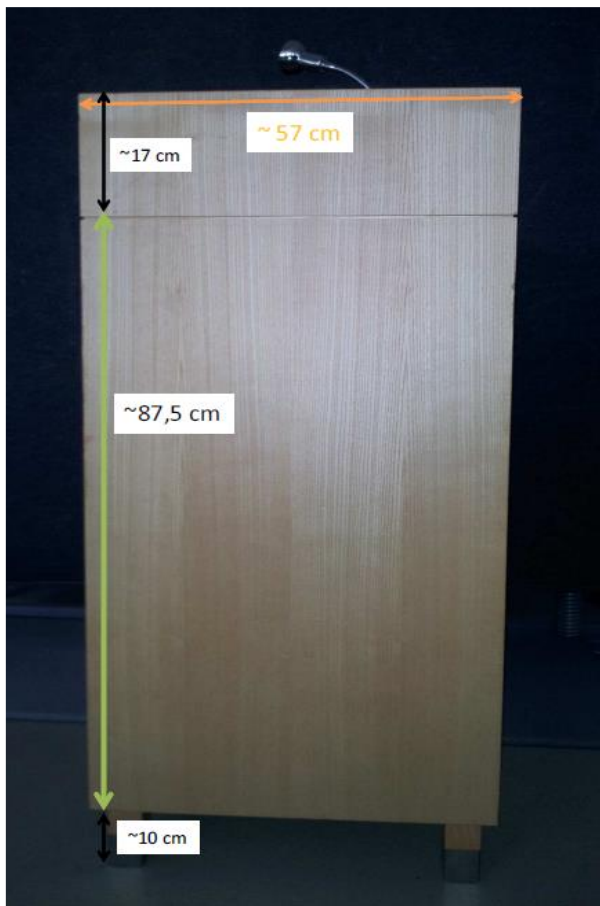

**CODE: PT2**

Position		Panel for chair tables, MCC	
Dimension (WxH)		1 400 mm	600 mm
Visible Area (WxH)		1 400 mm	600 mm
Sides		single	
Material		forex, 3mm	
Total pieces		-	

Unit Price 75,20 €

**Table provided by Messe  
(for MCC only!)**

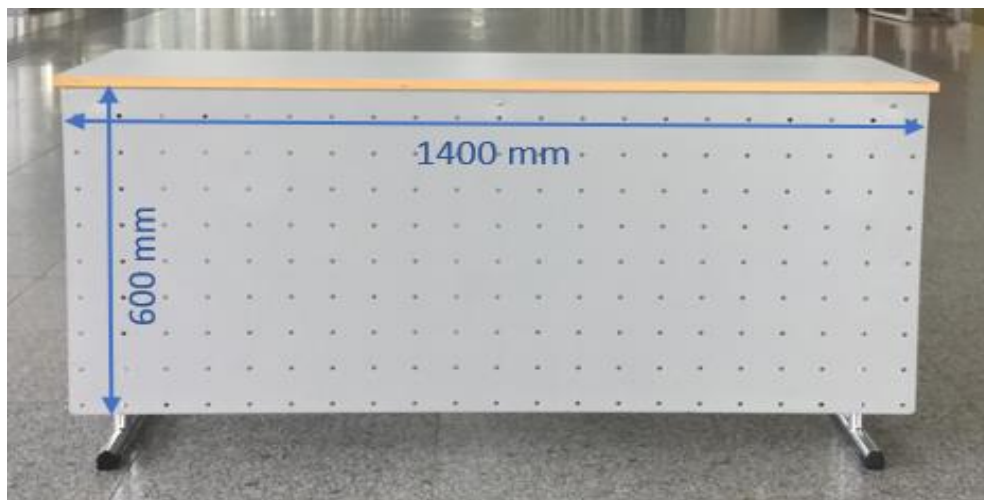

**CODE: CR1**

Position	<b>panel for counter - up</b>		
Dimension (WxH)	1 100 mm	340 mm	
Visible Area (WxH)	1 100 mm	340 mm	
Sides	single		
Material	foam board, 5mm		
Total pieces	-		

Unit Price 42,20 €

*Counters provided by Messe*



**CODE: CR2**

Position	<b>panel for counter - down</b>		
Dimension (WxH)	1 720 mm	1 000 mm	
Visible Area (WxH)	1 720 mm	1 000 mm	
Sides	single		
Material	forex, 3mm		
Total pieces	-		

Unit Price 105,50 €

*Counters provided by Messe*



**CODE: WA1**

Position	<b>panel for wardrobe tables MCC</b>		
Dimension (WxH)	1 880 mm	250 mm	
Visible Area (WxH)	1 880 mm	250 mm	
Sides	single		
Material	selfadhesive foil		
Total pieces	-		

Unit Price 66,20 €

**Tables provided by Messe  
(wardrobe only!)**



**ALLGEMEINE GESCHÄFTSBEDINGUNGEN („ACB“) DER Standout GMBH („Standout“)**

**I. ALLGEMEINER TEIL**

**1. Anbot/Vertragsverhältnis:** Für sämtliche Vertragsverhältnisse zwischen Standout und Auftraggebern (nachstehend „Kunden“) kommen ausschließlich diese AGB zur Anwendung. Entgegenstehende oder abweichende Bedingungen von Kunden gelten nur, soweit Standout diesen ausdrücklich schriftlich zugestimmt hat. Bei Miete oder Kauf gelten zusätzlich die besonderen Bestimmungen des II. und III. Abschnittes. Die Bestellung des Kunden ist für diesen verbindlich und nicht widerruflich. Sie kann von Standout binnen 30 Tagen ab Eingang bei Standout durch Erfüllung oder durch Übersendung einer schriftlichen Bestätigung oder einer Akontorechnung gemäß Punkt 13. angenommen werden. Hat der Kunde eine Lieferung zu einer bestimmten Messe bestellt und ist der Auftrag bis 1 Woche vor Veranstaltungsbeginn von Standout nicht angenommen worden, so hat der Kunde dies Standout unverzüglich mitzuteilen. Eine Verpflichtung von Standout, die Bestellung des Kunden anzunehmen, besteht nicht. Angebote der Standout an den Kunden sind unverbindlich und freibleibend.

**2. Mitwirkung des Kunden:** Mit der Bestellung verpflichtet sich der Kunde auch, die für die ordnungsgemäße Ausführung der Bestellung nötigen Unterlagen (etwa Pläne, Modelle, Genehmigungen, Richtlinien für die Ausführung etc.) gemäß den Terminvorgaben von Standout zeitgerecht zur Verfügung zu stellen. Diese Unterlagen müssen so beschaffen sein, dass eine einwandfreie Ausführung der Bestellung gewährleistet ist. Insbesondere hat der Kunde für sämtliche für die Ausführung der Bestellung erforderlichen Genehmigungen auf seine Kosten Sorge zu tragen. Ausführungs- und Materialmuster, die Standout dem Kunden zur Begutachtung vorlegt, müssen von diesem fristgerecht schriftlich bestätigt und retourniert werden, andernfalls gelten sie als „ohne Korrektur“ genehmigt.

**3. Leistungsumfang:** Sofern nicht anders angegeben, schuldet Standout dem Kunden nur die Lieferung der bestellten Gegenstände an den Ort der Übergabe. Montageleistungen und andere zusätzliche Leistungen muss der Kunde mit Standout gesondert vereinbaren.

**4. Ort der Übergabe:** Der Ort der Übergabe ist grundsätzlich die vom Kunden in der Bestellung angegebene Lieferadresse. Bestellt der Kunde eine Lieferung zu einer bestimmten Messe, so ist Ort der Übergabe der vom Kunden angegebene Stand in der vom Kunden bezeichneten Halle am Ort der betreffenden Messe.

**5. Zeitpunkt der Lieferung:** Der Zeitpunkt der Lieferung wird grundsätzlich von Standout festgelegt und dem Kunden bekannt gegeben. Nach Möglichkeit wird Standout hierbei Wünschen, die der Kunde in der Bestellung äußert, nachkommen oder sonst ein Einvernehmen mit dem Kunden herstellen. Bestellt der Kunde eine Lieferung zu einer bestimmten Messe, so hat die Lieferung jedenfalls während der vom betreffenden Messeveranstalter in seinen öffentlich zugänglichen allgemeinen Anmeldeunterlagen für Aussteller vorgegebenen Aufbauzeiten zu erfolgen, sofern mit dem Kunden nichts anderes vereinbart wird. Ansonsten muss Standout die Lieferung spätestens 30 Werktagen nach Annahme der Bestellung ausführen.

**6. Übergabe/Gefahrtragung:** Der Kunde hat dafür Sorge zu tragen, dass er selbst oder eine zur Übernahme der gelieferten Gegenstände befugte Person zum Zeitpunkt der Lieferung am Ort der Übergabe anwesend ist. Ist dies nicht der Fall, ist Standout berechtigt, die an den Kunden zu liefernden Gegenstände am Ort der Lieferung zurückzulassen. Standout ist nicht verpflichtet, die Legitimation der auf dem Stand bei Anlieferung des Mietgutes angetroffenen Personen zu überprüfen. Die von Standout an den Kunden zu liefernden Gegenstände sind übergeben, wenn der Kunde sie unbeanstaltet entgegennimmt oder Standout sie – im Falle der Abwesenheit zur Übernahme befugter Personen – zum abgesprochenen Zeitpunkt der Lieferung am Ort der Übergabe zurücklässt. Mit der Übergabe geht die Gefahr des zufälligen Untergangs auf den Kunden über.

**7. Urheberrechte:** Sämtliche im Zuge der Anboterstellung oder Vertragsdurchführung von Standout oder deren Bediensteten erstellten Unterlagen (insbes. Entwürfe, Pläne und Modelle) bleiben mit allen Rechten Eigentum der Standout und dürfen ohne vorherige Genehmigung weder Dritten zugänglich gemacht, noch veröffentlicht oder vervielfältigt werden. Sie dürfen vom Kunden ausschließlich für den vereinbarten Zweck verwendet werden und sind für den Fall, dass ein Vertragsverhältnis nicht zustande kommt oder wieder storniert wird, unverzüglich an Standout zurückzustellen.

**8. Datenschutz:** Die Verarbeitung personenbezogener Daten durch Standout erfolgt in Einklang mit den geltenden datenschutzrechtlichen Bestimmungen. Details zur Verarbeitung Ihrer Daten, insbesondere zu den konkreten Verarbeitungszwecken und Rechtsgrundlagen entnehmen Sie bitte der Datenschutzerklärung für Aussteller, die unter [www.standout.eu/datenschutzerklaerung](http://www.standout.eu/datenschutzerklaerung) abrufbar ist. Gibt der Kunde bei der Bestellung oder im Zuge der Vertragsabwicklung personenbezogene Daten Dritter (insbesondere Daten von Vertretern, Ansprechpartnern, Sachbearbeitern oder sonstigen Mitarbeitern seines Unternehmens) bekannt, ist er verpflichtet, die betroffenen Personen hierüber unverzüglich zu informieren und ihnen die Datenschutzerklärung der Standout zur Kenntnis zu bringen. Der Kunde haftet für jegliche Nachteile, die Standout aus einem Verstoß gegen diese Verpflichtung entstehen.

**9. Zustimmungserklärung gemäß § 174 TKG:** Der Kunde erteilt seine ausdrückliche Einwilligung, dass Standout ihm von Zeit zu Zeit E-Mails mit Informationen, Werbung und Umfragen zu eigenen Angeboten, Veranstaltungen und Leistungen („E-Mail-Newsletter“) zusendet oder ihn telefonisch zur Durchführung von Umfragen zu eigenen Veranstaltungen und Leistungen kontaktiert.

Diese Einwilligung kann jederzeit per E-Mail an [info@standout.eu](mailto:info@standout.eu) widerrufen werden.

**10. Werbeerlaubnis:** Der Kunde erteilt weiters seine Zustimmung, dass Standout die Kundendaten, Firmenwortlaut und Firmenlogo des Kunden, sowie Abbildungen des von Standout oder vom Kunden nach den Plänen von Standout errichteten Standes für eigene Werbezwecke (etwa durch Aufnahme in Referenzlisten, Darstellung im Internet, in Kundenzeitschriften oder in anderen Werbemitteln) verwendet.

**11. Rücktritt:** Für den Fall, dass (a) der Kunde mit Zahlungen an Standout (aus diesem Auftrag oder anderen Aufträgen) im Verzug ist, oder (b) ein Insolvenzverfahren gegen ihn eröffnet wurde bzw. droht, hat Standout das Recht, von diesem Vertrag zurückzutreten bzw. ungeachtet der Zahlungsverpflichtung des Kunden die eigene Leistung zurückzubehalten. Im Falle des Rücktritts durch Standout schuldet der Kunde eine Stornogebühr in Höhe des vereinbarten Entgelts.

**12. Preise:** Sämtliche Preise verstehen sich netto zuzüglich Umsatzsteuer in der jeweiligen gesetzlichen Höhe und zuzüglich aller sonstigen mit Abschluss und Durchführung des Auftrages verbundenen Steuern und Gebühren (z.B. Rechtsgebühr [siehe Punkt 24] oder Werbeabgabe). Die Preisangaben beziehen sich auf Lieferungen und Leistungen im Messezentrum Salzburg und Wien, die Verkaufspreise gelten ab Lager Salzburg bzw. Lager Wien. Bei anderen Leistungsorten werden Spesen, Diäten, Bearbeitungs- und Transportkosten separat verrechnet. Zusätzliche, nicht im Anbot enthaltene Leistungen, werden nach tatsächlichem Aufwand in Rechnung gestellt. Wird eine Rechnung von Standout über Wunsch des Kunden neu ausgestellt, etwa im Falle von Änderungen der Rechnungsanschrift oder anderer auf der Rechnung anzuführender Angaben des Kunden, so wird dafür ein pauschales Entgelt von € 49,00 exkl. USt. in Rechnung gestellt.

**13. Zahlungsbedingungen:** Standout hat das Recht, dem Kunden nach Erhalt der Bestellung eine Akontozahlung in Höhe von 50% des Auftragswertes in Rechnung zu stellen. Bei Kunden, die ihren Wohnsitz im Ausland haben, bei Neukunden oder bei Kunden, die bei früheren Bestellungen bereits mit Zahlungen im Verzug waren oder bei denen Zweifel an der Bonität bestehen, kann Standout Vorauszahlung von 100% des Auftragswertes verlangen. Lieferungen zu einer bestimmten Messe, die der Kunde erst eine Woche vor oder während der Veranstaltung bei Standout bestellt (maßgeblich ist das Einlangen der Bestellung bei Standout), werden nur gegen Vorauszahlung durchgeführt. Rechnungen sind nach Erhalt netto ohne Abzug zahlbar. Bei Zahlungsverzug schuldet der Kunde Verzugszinsen in Höhe von 12% p.a.. Der Kunde ist nicht berechtigt, wegen Gegenforderungen welcher Art auch immer aufzurechnen oder fällige Zahlungen zu verweigern.

**14. Tarifänderungen:** Bei Tarifänderungen (etwa Transport-, Versand- oder Energiepreise) erfolgt die Verrechnung auf Basis der jeweils zum Leistungszeitpunkt geltenden Tarife.

**15. Stornobedingungen:** Die Stornierung bestehender Verträge bzw. der Rücktritt von einer Bestellung ist nur hinsichtlich der für eine bestimmte Messe gemieteten bzw. gekauften Gegenstände zulässig und nur (a) gegen Bezahlung einer Stornogebühr sowie (b) sofern diese Gegenstände nicht von Standout für diesen Auftrag selbst produziert oder von Dritten erworben werden und (c) nur durch schriftliche Erklärung des Kunden, sofern diese bei gemieteten Gegenständen spätestens bis 2 Wochen und bei gekauften Gegenständen spätestens 4 Wochen vor Veranstaltungsbeginn bei Standout einlangt. Bei gemieteten Gegenständen beträgt die Stornogebühr bei Stornierung bis längstens 4 Wochen vor Veranstaltungsbeginn 30%, bis längstens 2 Wochen vor Veranstaltungsbeginn 50%, danach 100% des Netto-Auftragswertes, jeweils zuzüglich 1% Rechtsgeschäftsgebühr (bezogen auf den gesamten Mietzins). Bei gekauften Gegenständen beträgt die Stornogebühr bei Stornierung bis längstens 4 Wochen vor Veranstaltungsbeginn 50%, danach 100% des Netto-Auftragswertes. Zusätzlich zur Stornogebühr hat der Kunde der Standout alle im Zeitpunkt der Stornierung bereits entstandenen bzw. unvermeidbaren Kosten und Auslagen im Zusammenhang mit dem stornierten Auftrag zu ersetzen, falls diese Kosten den Betrag der Stornogebühr übersteigen. Wird die bestellte Ware nicht zum vereinbarten Zeitpunkt abgenommen, bleibt der Kunde zur Bezahlung des vollen Preises verpflichtet.

**16. Schriftlichkeit:** Soweit nach diesen AGB auf die Schriftform abgestellt wird, wird diesem Formerfordernis auch mit Erklärungen (ohne eigenhändige Unterschrift) Genüge getan, die per E-Mail von und an maßgebliche E-Mail-Adressen übermittelt werden. Maßgebliche E-Mail-Adressen im Sinne dieser Bestimmung sind: 16 a. für den Kunden: jene E-Mail-Adresse, mit der er für den von Standout betriebenen Online-Shop registriert ist, oder die er im Rahmen einer Bestellung (im Bestellformular) angegeben hat. 16 b. für Standout: die E-Mail-Adresse info@standout.eu.

**17. Rechtswahl:** Es gilt österreichisches Recht unter Ausschluss der Verweisungsnormen und des UN - Kaufrechts. Erfüllungsort und Gerichtsstand ist Salzburg Stadt.

**18. Haftungsbeschränkung:** Standout haftet nur für vorsätzlich oder grob fahrlässig verursachte Schäden und beschränkt auf den positiven Schaden.

## II. BESONDERE BESTIMMUNGEN FÜR MIETE

**19. Mietdauer:** Bestellt der Kunde einen Mietgegenstand für eine bestimmte Messe, so entspricht die Mietdauer der Dauer der Messe (inklusive der vom Messeveranstalter für den Aufbau vorgesehenen

Zeiten) sofern diese nicht mehr als 7 Tage beträgt. Eine längere Mietdauer muss der Kunde mit Standout jeweils gesondert vereinbaren.

**20. Verwendung:** Mietgegenstände dürfen ausschließlich für den vereinbarten Zweck verwendet und nicht Dritten überlassen werden. Sie sind unter möglichster Schonung der Substanz zu verwenden und dürfen ohne vorherige Zustimmung von Standout nicht verändert werden. Insbesondere dürfen besondere Kennzeichnungen auf dem Mietgut nicht entfernt und das Mietgut darf nicht beklebt, genagelt, gestrichen oder sonst wie beschädigt werden.

**21. Haftung und Rückgabe:** Das Mietgut ist unmittelbar nach Veranstaltungsende abholbereit zur Verfügung zu stellen. Gerät der Kunde in Verzug, so ist Standout berechtigt, die Gegenstände auf Kosten und Gefahr des Kunden für den Abtransport vorzubereiten. Das Einverständnis des Kunden wird hierzu vorausgesetzt. Der Kunde haftet verschuldensunabhängig für Verlust oder Beschädigung der Mietgegenstände ab Übergabe bis zur Rückgabe. Bei Beschädigungen oder Verlust ist Standout berechtigt, die fehlenden bzw. beschädigten Gegenstände dem Kunden zum Neupreis in Rechnung zu stellen. Von Standout festgestellte Mängel am rückgelieferten Mietgut werden dem Kunden angezeigt. Die Feststellungen gelten als anerkannt, wenn der Kunde nicht innerhalb einer Woche nach Zugang schriftlich widerspricht.

**22. Reklamationen / Gewährleistung:** Mietgegenstände werden in der Regel mehrfach verwendet und sind daher nicht neuwertig. Kleinere Abweichungen in der Ausführung, den Maßen und Farben gelten nicht als Mängel. Der Kunde hat bei Übergabe den ordnungsgemäßen Zustand und die Vollständigkeit des Mietgutes zu prüfen. Mit dem Empfang bestätigt der Kunde den mangelfreien Zustand der ihm überlassenen Sachen, es sei denn er erhebt unverzüglich eine schriftliche Mängelrüge. Hat der Kunde zu Recht die Mängelrüge erhoben, so ist die Gewährleistungspflicht von Standout auf Verbesserung beschränkt, soweit es sich bei der mangelhaften Sache um eine bereits gebrauchte handelt.

**23. Mietpreise / Zuschläge:** Für Lieferungen von Mietgegenständen zu einer bestimmten Messe, die später als 2 Wochen vor Messebeginn bei Standout bestellt werden (maßgeblich ist das Einlangen der Bestellung bei Standout), wird ein Last-Minute Zuschlag von 25% auf die Listenpreise verrechnet. Alle Preise gelten für eine Mietdauer von max. 7 Tagen. Bei einer Mietdauer von bis zu 10 Tagen wird ein Zuschlag von 15% verrechnet. Bei einer Mietdauer von mehr als 10 Tagen werden individuelle Preisvereinbarungen getroffen. Bei verspäteter Rückstellung von Mietgegenständen werden dem Kunden die der Standout durch die Verspätung tatsächlich entstandenen Schäden, mindestens aber 15% des gesamten Auftragswertes in Rechnung gestellt.

**24. Vergebührung:** Mietverträge unterliegen einer Rechtsgebühr von 1%. Bemessungsgrundlage ist das Mietentgelt einschließlich Umsatzsteuer sowie das Entgelt für mit der Miete zusammenhängende Leistungen. Die Vergebührung erfolgt durch Standout. Die Rechtsgebühr wird dem Kunden von Standout in Rechnung gestellt. Die Rechtsgebühr ist vom Kunden auch im Falle einer Stornierung zusätzlich zum Stornoentgelt zu bezahlen.

## III. BESONDERE BESTIMMUNGEN FÜR VERKAUF

**25. Eigentumsvorbehalt:** Die gelieferte Ware bleibt bis zur vollständigen Bezahlung des Kaufpreises sowie sämtlicher zum Zeitpunkt der Lieferung bestehender Forderungen Eigentum von Standout. Forderungen aus der Weiterveräußerung der gelieferten Ware tritt der Kunde schon jetzt im Voraus an Standout ab. Der Kunde hat seinen Abnehmern von der Abtretung Mitteilung zu machen und diese aufzufordern, nur noch direkt an Standout Zahlung zu leisten. Ersatzweise ist eine Bankgarantie in der Höhe des Auftragswertes vorzulegen. Die Kosten der Bankgarantie trägt der Kunde.

**26. Preise bei Drucksachen:** Bei Bestellung von Drucksachen gelten die angegebenen Preise nur bei Bereitstellung von druckfertigen Grafikdaten durch den Kunden. Allfällig erforderliche nachträgliche Druckdatenaufbereitung wird gesondert nach Aufwand in Rechnung gestellt.

**27. Verpackung und Versand:** Verpackungs- und Versandkosten werden gesondert verrechnet. Standout versendet nur auf Rechnung und auf Gefahr des Kunden. Eine Haftung ist ausgeschlossen. Beschädigungen muss sich der Empfänger sofort bescheinigen lassen und dem Transporteur melden.

**28. Reklamationen:** Mängel sind vom Kunden bei sonstigem Verlust jeglicher Mängelhaftung innerhalb von 2 Tagen nach Übernahme schriftlich anzuzeigen.

Please find the english version here: [www.standout.eu/en/terms-and-conditions/](http://www.standout.eu/en/terms-and-conditions/)

**GENERAL TERMS AND CONDITIONS ('terms') OF Standout GMBH (Standout)**

**I. GENERAL CONDITIONS**

**1. Offers and contractual relationships:** All contractual relations between Standout and clients/customers (hereinafter to be referred to as the 'customer') shall be solely subject to these 'terms'. All other contradictory or deviating conditions mentioned by the customer shall only be accepted on condition they have been explicitly approved by Standout. In cases of hire or purchase the additional conditions in sections II and III shall also apply. Orders placed by the customer are binding and irrevocable. Standout shall be entitled to accept this order within 30 days of receipt by Standout by way of provision/completion, or the sending of written confirmation, or by issuing an invoice for part payment according to point 13. If the customer has placed an order for goods/services for a specific trade fair and the order has not been officially confirmed by Standout by 1 week before the beginning of the event, the customer shall be obliged to inform Standout of this fact immediately. There shall be no obligation on the part of Standout to accept an order placed by a customer. Quotes or offers provided by Standout shall be non-binding.

**2. Customer cooperation:** On order placement the customer shall also become obliged to ensure proper and punctual provision of all documentation according to the dates agreed (i.e. plans, models, permits, and guidelines for execution etc.) that shall be necessary for completion of the order by Standout. This documentation must be provided in such a form as to ensure faultless completion of the order. In particular, the customer shall be responsible for the collection of, and payment for (at his/her own expense), all permits required for the execution of the order. Samples of items and materials provided to the customer of Standout for inspection, must be confirmed as accepted in writing and returned within the deadline provided; otherwise they will be considered to have been 'accepted without changes'.

**3. Scope of services:** If not stated otherwise, Standout shall only be obliged to deliver the items ordered to the place determined for collection. The customer shall be obliged to place a separate order with Standout for assembly/dismantling and other additional services.

**4. Venue for collection:** As a general principle the venue for collection shall be the address provided in the order for deliveries. If the customer places an order for a delivery to a specific trade fair the venue for collection shall be at the stand in the hall named by the customer at the trade fair in question.

**5. Time of delivery:** As a general principle the time of delivery shall be determined by Standout and announced to the customer. When possible Standout will take into account wishes stated

by the customer in the order; or seek to make an agreement with the customer. If the customer orders a delivery to a specific trade fair the delivery must be conducted during the assembly times provided by the trade fair organiser in the freely and publicly available general registration forms for exhibitors, unless otherwise agreed with the customer. Otherwise, Standout shall be bound to complete service provision within 30 working days after acceptance of the order at the latest.

**6. Delivery/Transfer of risk:** The customer must ensure that he/she himself/herself, or a person authorised by the customer to the purpose of receiving the goods, is present at the point of delivery at the agreed time of delivery. If this is not the case Standout shall be entitled to leave the goods intended for handover to the customer at the agreed point of delivery. Goods to be delivered by Standout to the customer shall be considered to have been handed over if the customer takes them without complaint or if, at the agreed time and place of delivery, Standout deposits the goods intended for collection by the customer or by his/her authorised representative. Once the goods have been handed over, liability for risks of coincidental damage or destruction of goods shall be transferred to the customer. Standout is not obliged to inspect the accreditation of people present at the stands when the goods for rent are delivered.

**7. Copyrights:** All documents and drafts produced by Standout or their employees and subcontractors for the purpose of producing an offer or for the purpose of sealing a contractual agreement (particularly drafts, plans and models) remain subject to complete ownership by Standout and may not be made accessible to third parties, published or copied without receiving prior permission from Standout. The customer may only use such documents for the sole purpose agreed. If a contractual relationship does not materialise or is subsequently cancelled, all such documentation must be returned to Standout immediately.

**8. Data Protection:** The processing of personal data by Standout takes place in accordance with the applicable data protection rules and regulations. For details on the processing of your data, in particular for the specific processing purposes and legal basis, please refer to the data privacy policy for exhibitors, which is available at [www.standout.eu/privacy-policy](http://www.standout.eu/privacy-policy). If the customer notifies Standout of personal data of third parties (in particular data of representatives, contact persons, agents or other employees of his company) within the order or in the course of the contract, he is obliged to inform the persons concerned without any delay and to provide them with the data privacy policy of Standout. The customer is liable for any disadvantages incurred by the organiser in breach of this obligation.

**9. Consent according to Section 174 TKG:** The customer expressly consents to Standout sending him emails from time to time containing information, advertising and surveys on our own offers, events and services ("email newsletter"), or contacting him by phone to conduct surveys on own events and services. This consent can be revoked at any time by email to [info@standout.eu](mailto:info@standout.eu).

**10. Permission to advertise:** Furthermore, the customer shall permit Standout to use customer details, company names and corporate logos, as well as pictures of stands erected by Standout, or erected according to plans made by Standout or the customer for Standout's own advertising purposes (such as for addition to reference lists, presentation on the internet, entries in customer magazines or in other forms of advertising).

**11. Rescission:** If (a) the customer is in arrears with payments to Standout regardless of whether these debts stem from this or other orders; or (b) insolvency proceedings have been initiated against him/her or there is a threat of such proceedings being initiated, Standout shall be entitled to withdraw from the contract and to withhold the provision of services, regardless of the duty of the customer to pay. Should Standout choose to withdraw from the contract the customer shall be liable to pay the agreed cancellation fee.

**12. Prices:** All prices are quoted net, plus the applicable statutory VAT rate, plus all other taxes, duties and contributions due on placement, acceptance, execution and completion of the order (i.e. legal transaction fees [pt. 24] and advertising duties). Price information pertains to deliveries and services at the exhibition centres in Salzburg and Vienna; sales prices are quoted ex works in Salzburg or Vienna. At other points of service the expenses, allowances, handling and transportation costs may be invoiced separately. Additional services not included in the offer shall be invoiced at the actual price of services and goods used. If Standout revises an existing invoice based on a customer's request, for example to change the billing address or other information on the invoice, this will be subject to a flat fee of € 49,00 (plus VAT).

**13. Conditions of payment:** Standout reserves the right to demand a part payment of 50% of the order value on receipt of the order. If a customer resides in a foreign country, is a new customer or a customer who has previously been late on a payment or whose creditworthiness is not assured, Standout is entitled to demand a full payment of 100% of the order value in advance. Deliveries made to a specific trade fair that the customer only ordered from Standout from a week before the fair up to during the fair itself, (the valid time of receipt being the date upon which Standout officially received the order), will only be completed after a full advance payment. The customer is at no point entitled to set off or withhold due payments against counterclaims of any kind.

**14. Changes in fees and prices:** Should prices or fees change (i.e. transport, forwarding or energy prices), charges shall be based on the prices and fees valid at the moment of service provision.

**15. Cancellation terms:** The cancellation of an existing contract or order shall only be permitted for items hired or purchased for a particular trade fair, and only if (a) a cancellation fee is paid, (b) these items were not produced by Standout, or ordered from a third party by Standout for this contract, and (c) only if notification is submitted by the customer in writing, and received by Standout no later than 2 weeks prior to the beginning of the event for hired items, and 4 weeks prior to the beginning of the event for purchased items. As regards hired items, the fee for a cancellation received at the latest 4 weeks prior to the beginning of the event shall

30% of the net order value. For a cancellation received at the latest 2 weeks prior to the beginning of the event this percentage shall rise to 50%, thereafter 100%. In each case, this will also be subject to payment of an additional 1% of the total rental fee to cover legal transactions. As regards purchased items, the fee for a cancellation received at the latest 4 weeks prior to the beginning of the event shall be 50% of the net order value, thereafter 100%. In addition to the cancellation fee, the customer shall be obliged to compensate Standout for all costs, unavoidable expenditure and financial outlay by Standout in the context of the cancelled contract/order up to the time of cancellation, to the amount to which they exceed the total amount of the cancellation fee. If the item ordered is not picked up at the date and time agreed, the customer shall be obliged to pay the full price for the item.

**16. The written form:** Wherever these terms and conditions insist on the use of written communication, this obligation will also be considered to have been fulfilled in the case of declarations made (without a personal signature) that have been sent from and to an authoritative e-mail address. An authoritative e-mail address in compliance with this condition is: a. for the customer: the e-mail address with which he/she is registered with the online shop run by Standout, or the one that has been given in the course of placing an order (using the order form) and b. for Standout: the following e-mail address: info@standout.eu.

**17. Choice of legal basis:** Austrian law shall apply. Legal reference provision norms for international commercial disputes and the United Nations Convention on Contracts for the International Sale of goods shall not apply. Legal venue is the city of Salzburg.

**18. Limited liability:** Standout shall only be held liable for damage caused by deliberate or grossly negligent behaviour and only for positive damage.

## II. SPECIAL RENTAL CONDITIONS

**19. Rental period:** If the customer orders a rentable object for a specific trade fair the rental period shall be for the duration of the trade fair (including the assembly period provided by the fair organiser) as long as the entire period does not exceed 7 days. A longer rental period must be agreed between the customer and Standout in a separate agreement.

**20. Usage:** Rental objects may be solely used for the agreed purpose and may not be used by third parties. They must be subjected to the least wear, tear and stress as possible and may not be changed without prior receipt of consent from Standout. Special markings on items for rent may under no circumstances be removed by the customer. The customer shall be prohibited from applying any stickers to the said goods, from gluing items to these goods, from attaching items with nails or staples of any type, and from damaging the goods for rent in any way.

**21. Liability and return of goods:** The rented object must be made available for collection immediately after the event has ended. If there is a delay Standout shall be entitled to prepare the rented objects for collection at the risk and expense of the customer. The consent of the customer shall be a prerequisite in this regard. Regardless of the question of guilt, the customer shall be held liable for loss of, or damage to, rented objects from the point of handover to the point of return. In cases of damage or loss Standout shall be entitled to invoice the customer for the price of brand new replacements for missing or damaged objects. Any faults identified by Standout on returned rented goods will be reported to the customer. These findings shall be considered to have been accepted if the customer does not object in writing within 1 week of receiving this information.

**22. Complaints / Warranty:** As a general principle rental objects are used on a number of occasions and are thus not classified as being brand new. Small deviations in the versions, dimensions and colours available cannot be categorised as faults. The customer shall be obliged to ensure the rented item(s) is (are) complete and in full working order when it is (they are) handed over to the customer. Receipt of the rented goods by the customer shall signify confirmation of the fault-free condition of the items in his/her possession, unless a written complaint specifying defects is submitted immediately. If the customer's complaint is justified, Standout's obligation to honour warranty rights shall be limited to rectification of the fault(s) as regards items that have already been used.

**23. Rental prices / surcharges:** As regards deliveries of hired objects to a specific trade fair, which have been ordered from Standout later than 2 weeks before the trade fair commences (the valid time of receipt being the date upon which Standout officially received the order), there will be a last-minute surcharge of 25% added to the listed price. All prices are intended for a maximum rental period of 7 days. A surcharge of 15% will be charged for a rental period of up to 10 days. Special agreements shall be made with each individual customer for events lasting more than 10 days. If rental objects are returned late, the customer shall be liable to pay Standout for all actual resultant costs or losses. A minimum of 15% of the full order value shall be charged in such cases.

**24. Billing:** Rental contracts are subject to a legal fee of 1%. The fee assessment is based on the rental charge including value-added tax, along with compensation for the services associated with the rent. Standout issues the billing. The customer will be invoiced for the legal fee by Standout. The customer is obliged to pay the legal fee even in case of a cancellation in addition to the cancellation fee.

## III. SPECIAL SALES CONDITIONS

**25. Retention of title:** The goods delivered shall remain the property of Standout until the purchase price and all other debts existing at the time of delivery have been paid in full. Any payment gained from the selling-on of any goods delivered shall be forfeited a priori to Standout. The customer shall be obliged to inform his/her customer of this cession and to demand the said customer pay directly to Standout only. Alternatively, a bank guarantee covering the total order value can be accepted in its place. The costs of a bank guarantee shall be borne by the customer.

**26. Prices of printed materials:** When printed materials have been ordered the estimated prices provided shall only be valid if these materials have been produced using graphics and texts provided in a print-ready form by the customer. All subsequently necessary processing work on print graphics and text will be invoiced separately.

**27. Packaging and forwarding:** Packaging and forwarding costs are invoiced separately. Standout only delivers on account and at the risk of the customer. No liability shall be accepted on the part of Standout. The recipient must certify all cases of damage immediately and report them to the forwarding agent.

**28. Complaints:** Any faults, damage or omissions must be reported in writing within 2 days of receipt of goods, otherwise all claims for damages shall be rendered null and void.